

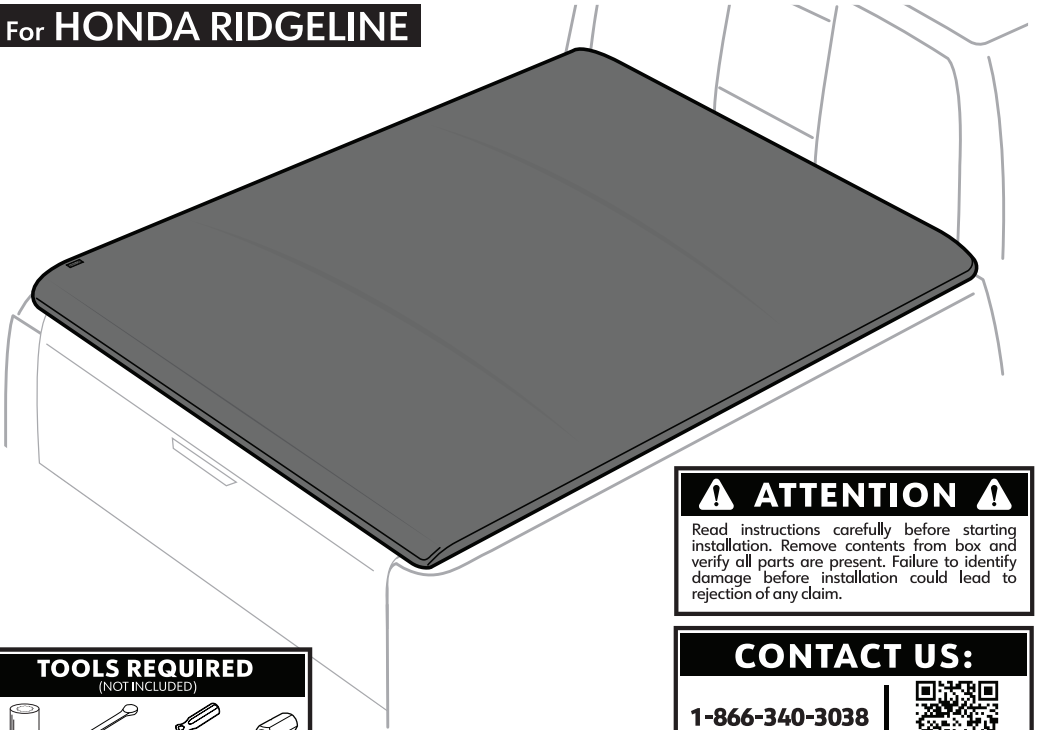

TYGER®

T1X | SOFT ROLL-UP COVER IN FABRIC

For HONDA RIDGELINE



⚠ ATTENTION ⚠

Read instructions carefully before starting installation. Remove contents from box and verify all parts are present. Failure to identify damage before installation could lead to rejection of any claim.

TOOLS REQUIRED (NOT INCLUDED)

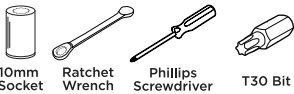

10mm Socket Ratchet Wrench Phillips Screwdriver T30 Bit

CONTACT US:

1-866-340-3038



LIVE CHAT

PARTS LIST

(ONLY MARKED ITEMS ARE INCLUDED)

Bed Cover



Side Rails (L & R)



SP-BC1029 Driver/Passenger Sides Front Brackets (A)



SP-BC1030 Driver/Passenger Sides Middle Brackets (B)



SP-BC1031 Driver/Passenger Sides Rear Brackets (C)



SP-BC1028 M6 Screw + Washer



SP-BC0003 Front Seal Strip 170 x 2.5 x 1cm



SP-BC0012 Bulkhead Side Seal Strip 8.0 x 1.0 x 0.6cm



SP-BC0013 Bulkhead Side Seal Foam 5.0 x 4.5 x 0.6cm





1 APPLYING SEAL STRIPS ⓘ

IF THE TRUCK'S FRONT BED RAIL IS LOWER THAN THE SIDES, USE THE PROVIDED WEATHER SEAL STRIPS. GAPS ON THE FRONT BED AND TAILGATE CAN CAUSE NOISE AND FLAPPING ISSUES WHILE DRIVING ALONG WITH WATER LEAKAGE.

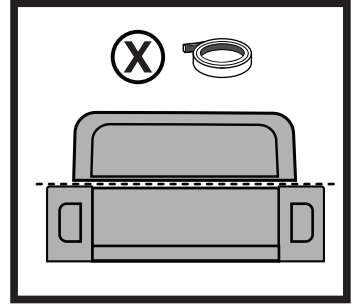
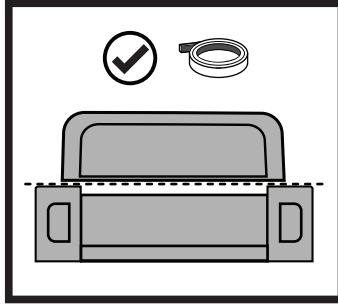

a

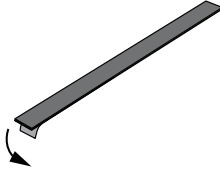

b

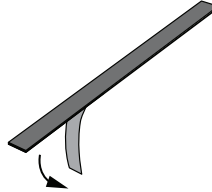

c

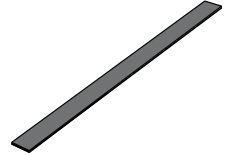

d

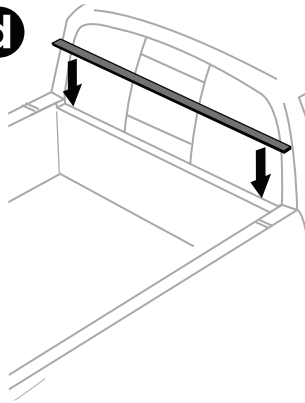

e

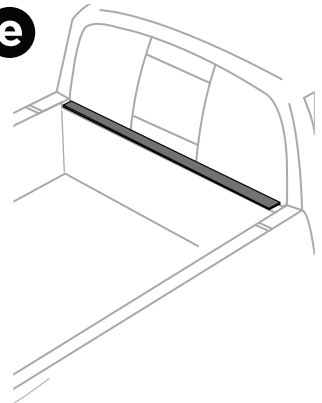

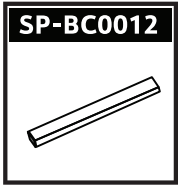

f

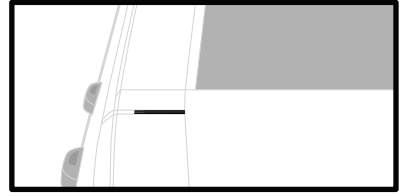
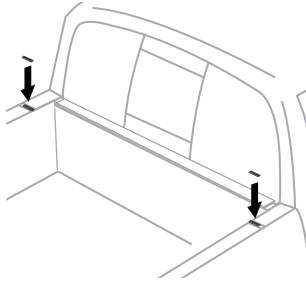

g

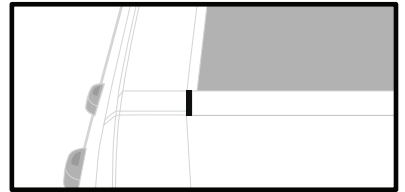
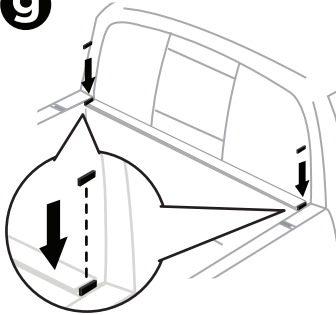

2 REMOVE THE FACTORY SCREWS

• FROM 6 INDICATED LOCATIONS.

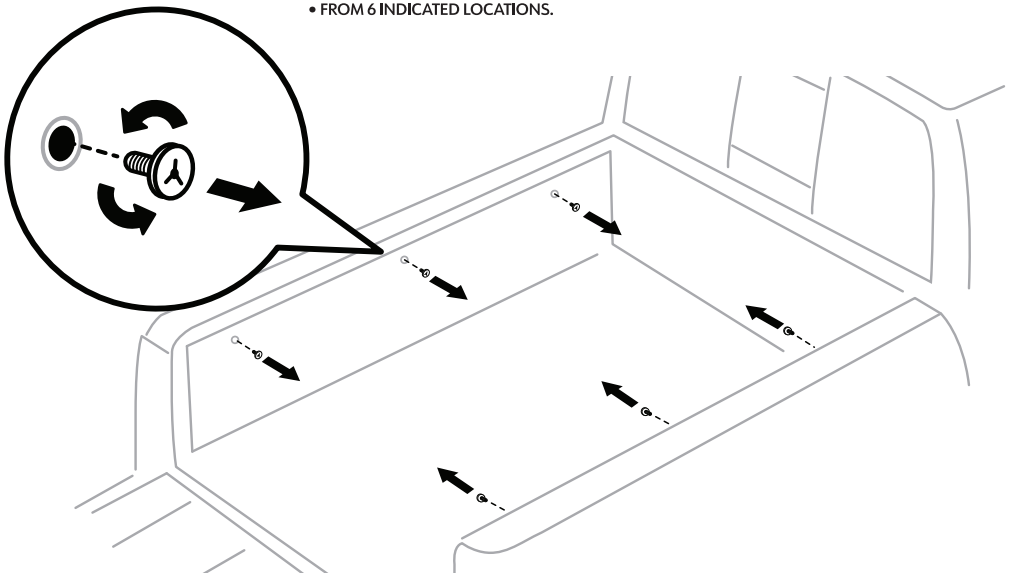



YOU NEED

Phillips-Head
Screwdriver

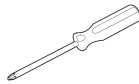

ATTENTION

Lift tarp while inserting
side rail to prevent
tearing!

3 ASSEMBLING COVER

- PLACE COVER ASSEMBLY ON FRONT TRUCK BED RAIL AGAINST THE CAB.
- LOOSEN THE SCREW IN BULKHEAD ASSEMBLY ON BOTH SIDES, THEN SLIDE IN THE SIDE RAILS.
- REINSTALL AND TIGHTEN SCREWS TO ATTACH SIDE RAILS TO COVER ASSEMBLY.

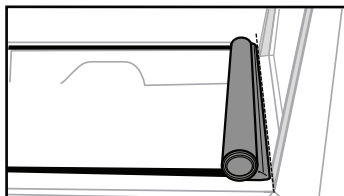
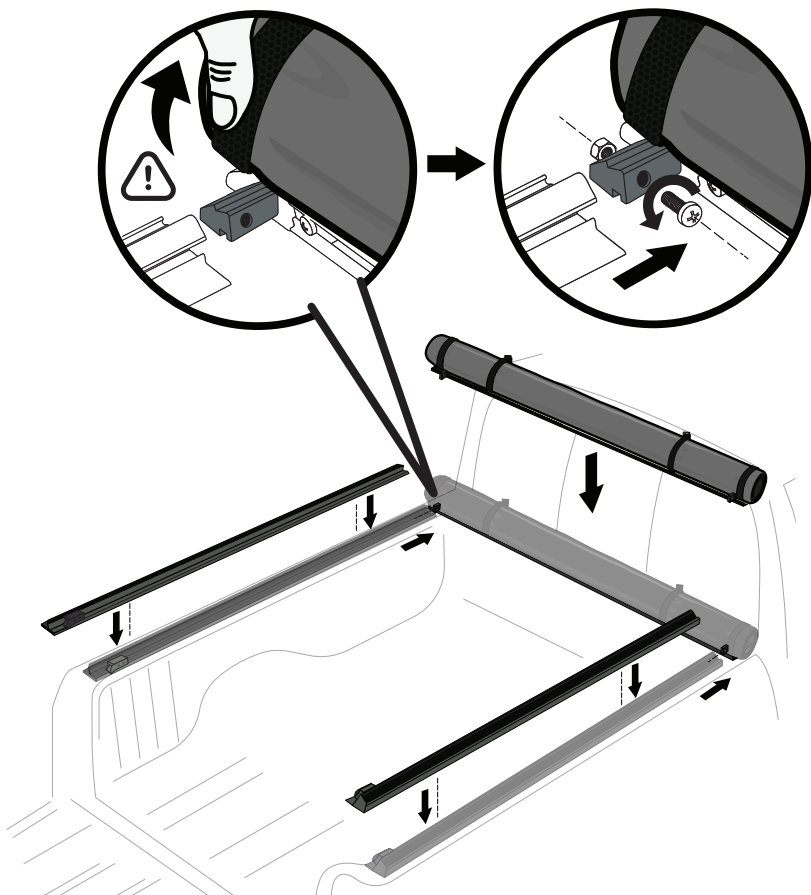

The base of the front cover assembly must be positioned right up against the left and right rear window post panels. Make sure there is no gap between the weather seal tape and the cover base.

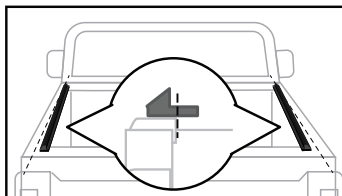

Cover side rails will taper off towards the tailgate and may not stay parallel; they will hover over the cargo space so rear clamps can reach the railings.

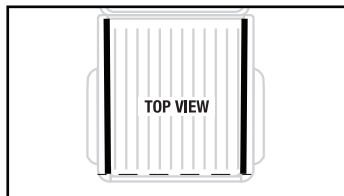

The cover side rails may not seem parallel with the bed panel railings but both side rails must be symmetrically spaced between each other and their tailgate ends must be aligned for proper latching.



NOTE

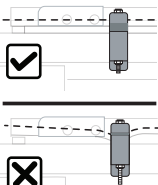

DO NOT
over-tighten
the clamps

ATTENTION

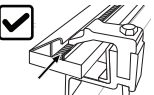

Inside Channel

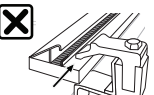

Out of Channel

4 POSITIONING SIDE RAILS & CLAMPS



• FIRST REMOVE CLAMP ASSEMBLIES FROM THE PACKAGE. THEN MATCH LETTERS **A**, **B** AND **C** ETCHED ON CLAMPS WITH CORRESPONDING POSITIONS ETCHED ON SIDE RAILS. PROCEED TO HOOK THE UPPER CLAMP INTO THE INNER CHANNEL OF TONNEAU COVER SIDE RAILS. THEN ADJUST THE POSITION OF THE BOTTOM HOLE ON THE CLAMPS SO THEY LINE UP WITH THE FACTORY SCREW HOLES.

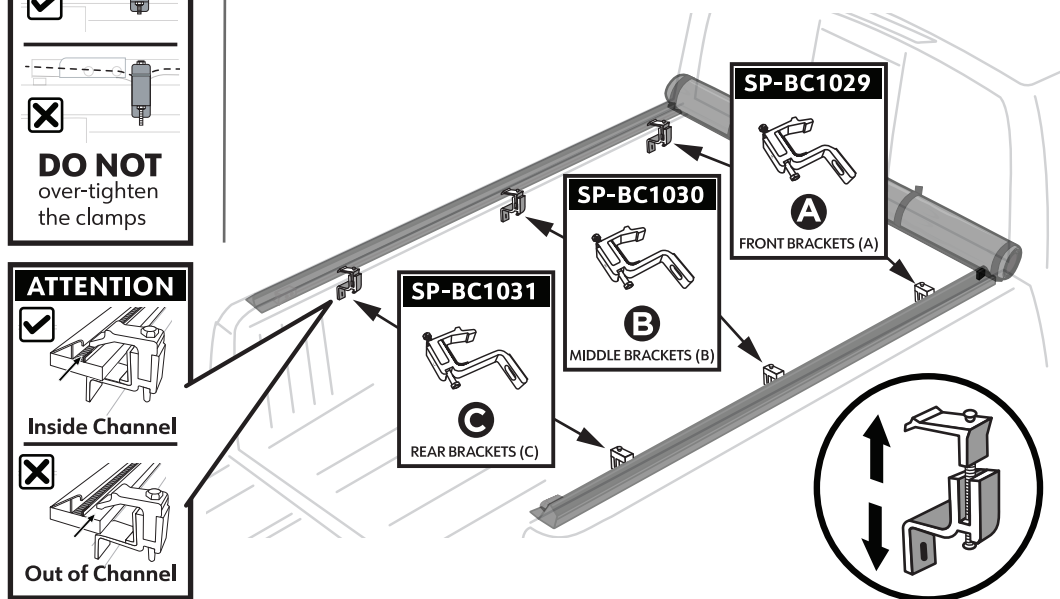

5 INSTALL BRACKETS

• USE (1) SCREW WITH (1) WASHER EACH TO FASTEN THE 6 BRACKETS ON BOTH SIDES TO THE FACTORY HOLES.

SP-BC1028

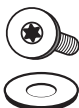

M6 Screw
+ washer

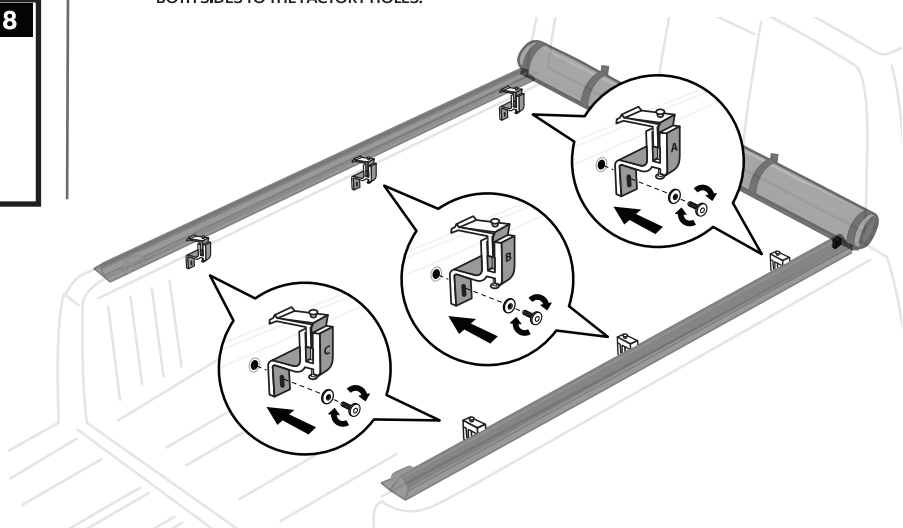



ATTENTION

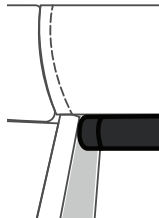

Incorrect positioning of the crossbars can cause water to pool on the cover.

ATTENTION

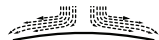

Horizontal crossbars are arched by design to help drain and prevent water pooling. Make sure the arched side is facing up during installation.

6 ROLLING OUT THE COVER

- UNHOOK THE SAFETY STRAPS.
- MAKE SURE THE ENDS OF THE CROSSBARS ARE RESTING ON THE SIDE RAIL LEDGES AND CROSSBARS ARE ARCHED UPWARD.

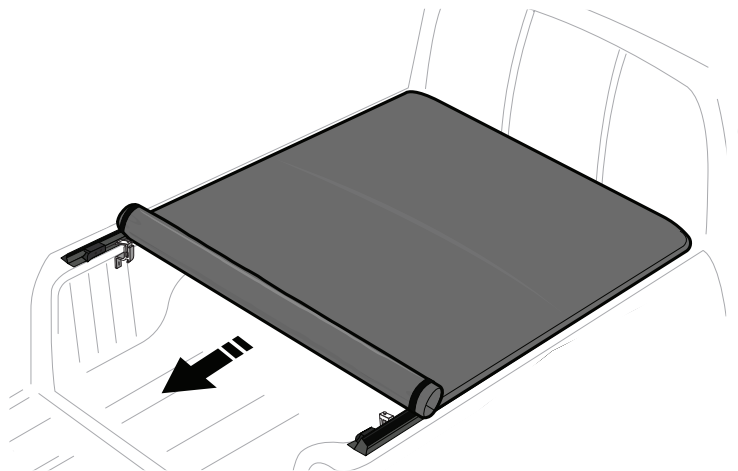

7 LOCKING THE COVER

- PUSH DOWN THE END OF THE COVER WITH SUFFICIENT FORCE TO CLOSE IT.
- THE COVER MUST BE CLOSED FIRST BEFORE YOU SHUT THE TAILGATE.

WARNING!

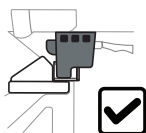

In Channel

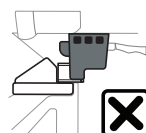

NOT In Channel

NOTE

For latching issue, refer to PAGE 13 for trouble shooting instruction.

a

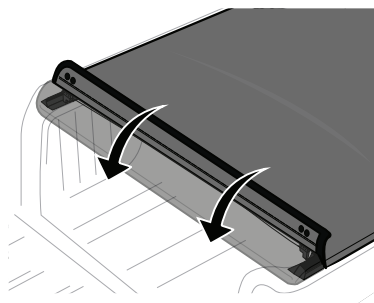

b

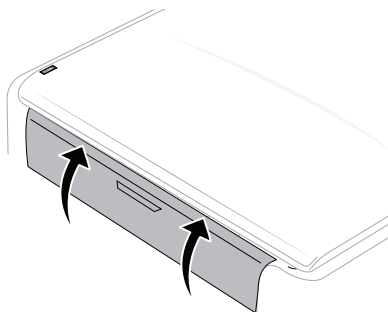

CLICK!!!



NOTE



Velcro Strips must be fully fastened to prevent water from leaking in.

8 STRAIGHTENING OUT THE COVER

- STRETCH OUT THE COVER TARP ON BOTH SIDES TO REMOVE ANY WRINKLES AND MAKE SURE BOTH VELCRO STRIPS ARE PROPERLY FASTENED AND SEALED TO PREVENT WATER LEAK.

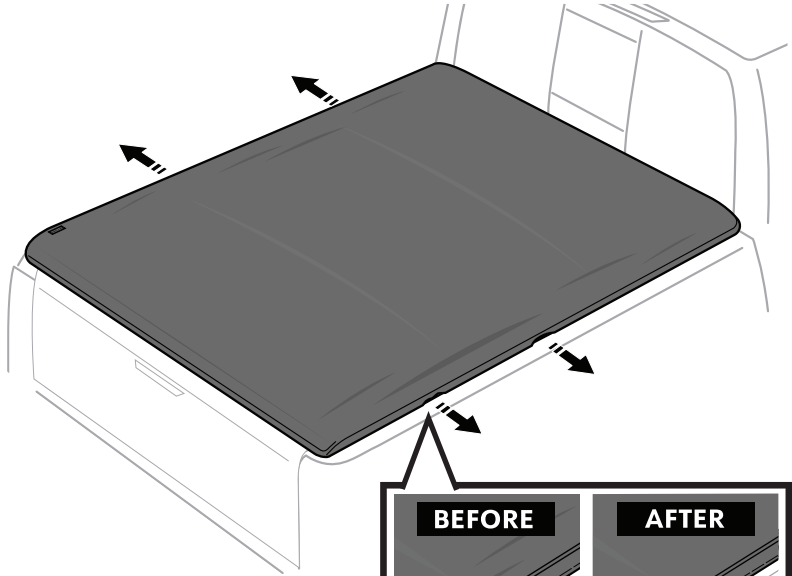

SEAL STRIP



9 CHECKING FOR GAPS

- WITH THE TAILGATE OPEN, VISUALLY INSPECT FOR LIGHT LEAKING THROUGH THE GAPS. APPLY ADDITIONAL SEALING STRIPS TO FILL THE GAPS THEN REINSPECT AND REPEAT.

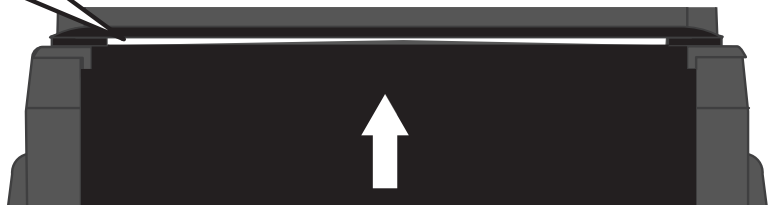
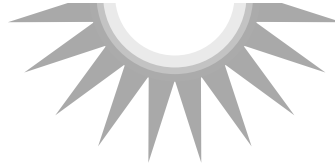

INSTALLATION COMPLETE!!!

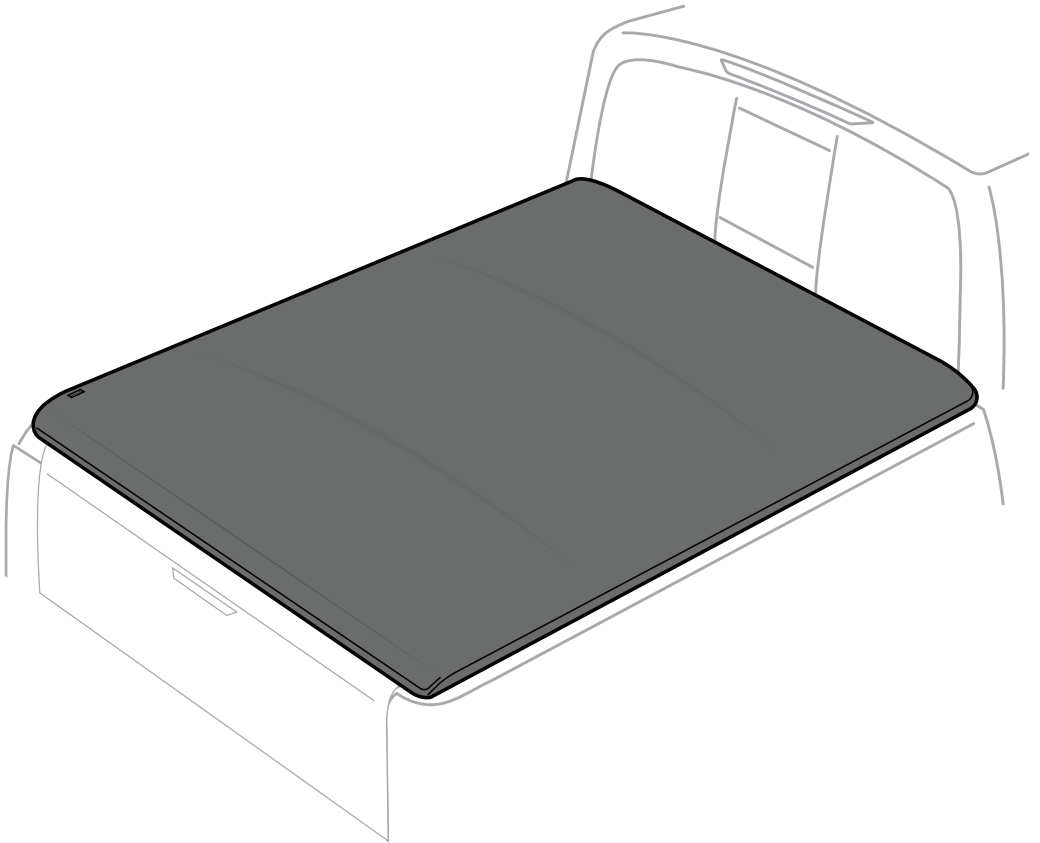

AFTER INSTALLATION

10 RELEASING THE COVER ⓘ



NOTE

Pressing down on the cover edge will improve the release.

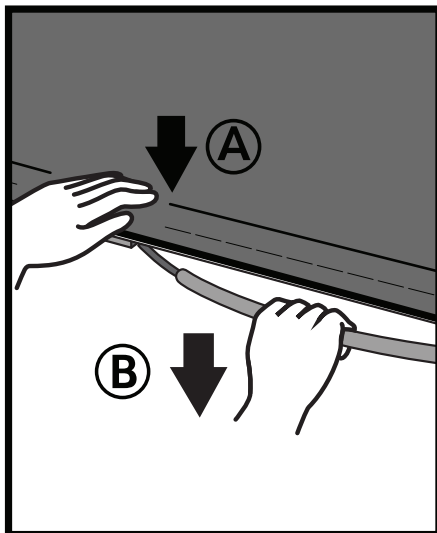

• OPEN THE TAILGATE AND PUSH DOWN AGAINST THE COVER EDGE WITH ONE HAND.



• PULL ON LATCH CABLE TO RELEASE THE COVER WITH THE OTHER HAND.

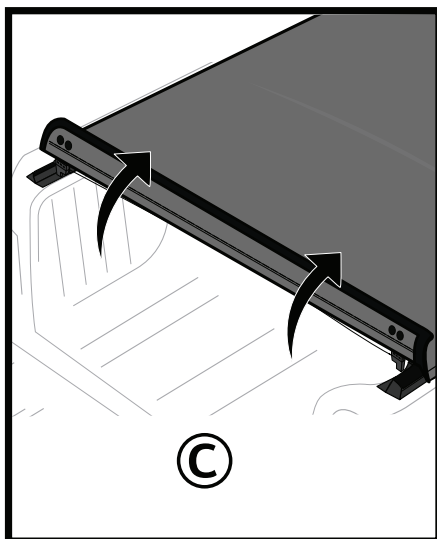

• ROLL UP THE COVER CLOSELY.

11 ROLLING UP THE COVER ⓘ



ATTENTION

Make sure the cover is free from any debris before rolling it up. Safety straps must be buckled and tightened before driving.

NOTE

Cover may not fully cover all the way to the outer edges of the bed rails due to small variance in bed sizes from different year models.

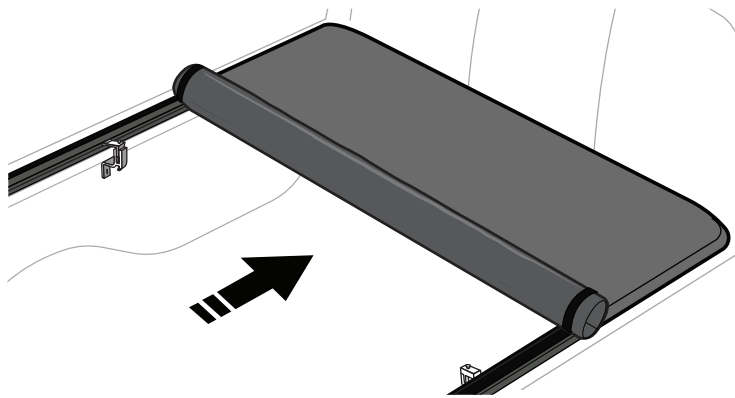

DO NOT
overload cargo



Secure strap buckles
before driving



Remove snow before
rolling up cover



Use water and
soap to clean.
Avoid abrasive
chemical cleaners

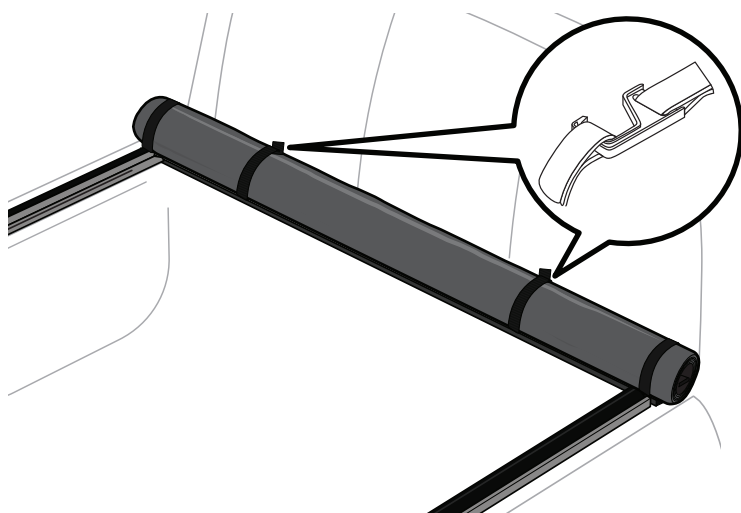

12 TONNEAU COVER CARE & MAINTENANCE

❄️ COLD WEATHER USE – IMPORTANT

- DO NOT operate the vehicle with snow or ice buildup on the cover
- Gently remove any snow buildup from the cover before operation
- If the cover is frozen or stuck, DO NOT force it to roll or unroll
- If frozen, allow the cover to thaw naturally. DO NOT use hot water, chemicals, or de-icing agents
- DO NOT use sharp or hard objects to remove ice or snow, as this may damage the cover

⚠️ CLEANING TIPS

Follow these cleaning guidelines to help prevent damage to the fabric and seams, protect the waterproof barrier, and minimize fading:

- DO NOT use pressure washers or hot water
- Tonneau cover must be removed before using an automated car wash
- Rinse with a standard garden hose using a shower, fan, or mist setting
- Avoid using jet or power stream modes at close range (<1 ft)
- For dirt or stains, use a soft sponge or cloth with mild soap and luke warm water (max 30°C / 86°F)
- Avoid scrubbing, bleach, or harsh chemicals
- Rinse thoroughly and air dry completely before closing or storing
- Avoid prolonged soaking to water and detergent



Gentle
Hand Wash



No
Harsh Chemicals



DO NOT
Pressure Wash



DO NOT
Iron



NO Automated
Car wash



Air Dry

13 SELF-MAINTENANCE THE TENSION CONTROL SYSTEM ⓘ

NOTE: TENSION PLATE ADJUSTMENT IS NOT REQUIRED FOR BRAND-NEW TONNEAU COVERS. IF THE TENSION BETWEEN THE BULKHEAD & TENSION PLATE HAS BECOME LOOSE OR TIGHT OVER TIME, YOU CAN ADJUST THE TENSION PLATE POSITION TO IMPROVE THE TENSION CONTROL.

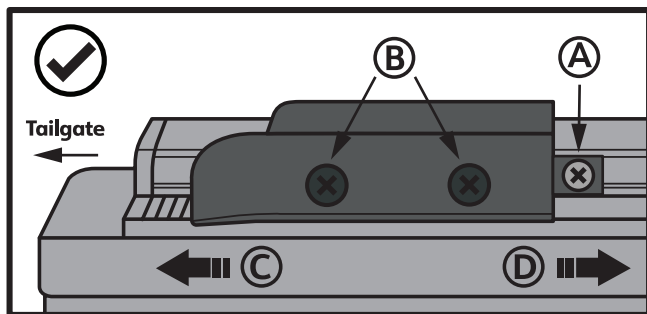
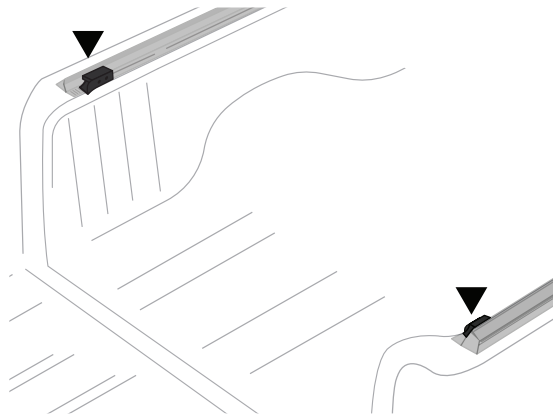

- (A)** • FIRST LOOSEN THE FRONT SCREW IN THE RAIL CHANNEL. DO NOT FULLY REMOVE THIS SCREW.
- (B)** • THEN LOOSEN THE 2 SCREWS IN THE TENSION PLATE BLOCK. DO NOT FULLY REMOVE THESE SCREWS. THIS ALLOWS THE TENSION PLATE TO SLIDE BACK AND FORTH.
- (C)** • TO INCREASE THE TENSION (LATCHING IS TOO LOOSE), MOVE THE TENSION PLATE TOWARDS THE TAILGATE. RE-TIGHTEN FIRST THE **(A)** THEN **(B)** SCREWS.
- (D)** • TO DECREASE THE TENSION (LATCHING IS TOO TIGHT), MOVE THE TENSION PLATE TOWARDS THE FRONT. RE-TIGHTEN FIRST THE **(A)** THEN **(B)** SCREWS.



NOTE

Only move one increment at a time. Each increment gives you 1/8" of tension adjustment. Apply the same adjustment to both sides' tension plates.

YOU NEED

Phillips-Head
Screwdriver

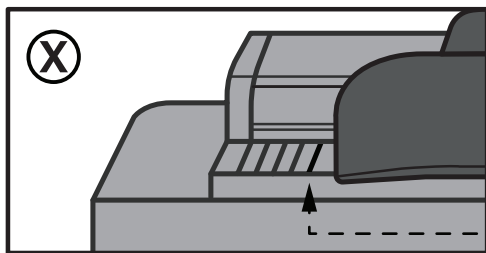
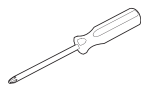

⚠ ATTENTION

• DO NOT ADJUST THE TENSION PLATE BEYOND THE LAST INCREMENT LINE.

14 COVER DOESN'T STAY LATCHED?

- MAKE SURE THE LOCKING CLIP ON BOTH SIDES ARE COMPLETELY INSERTED INTO THE CHANNEL ON THE SIDE RAILS TO AVOID END OF THE COVER BECOMING UNLATCHED.

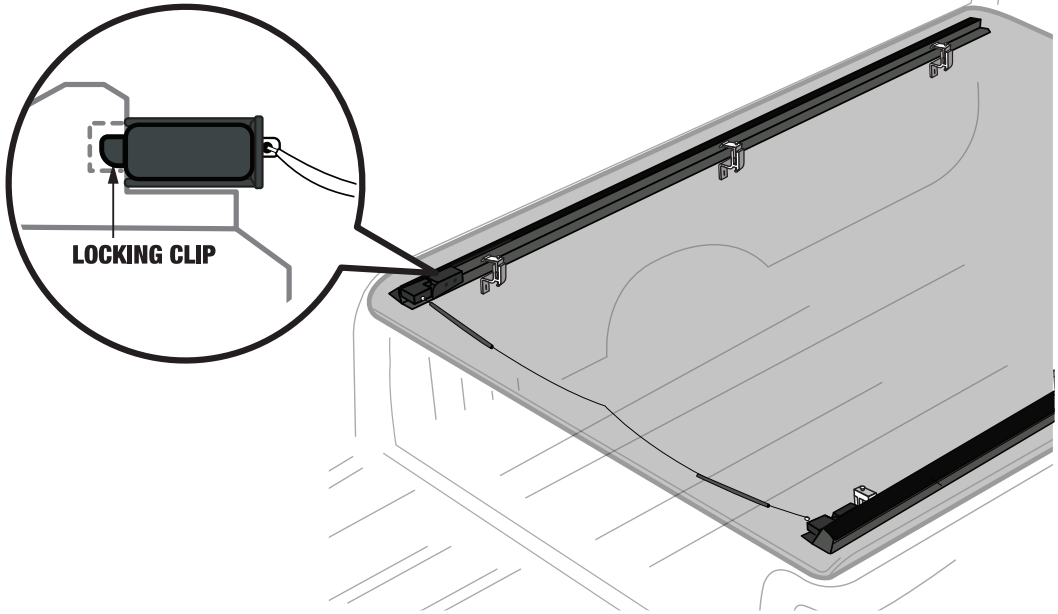

- 15** • IF COVER DOESN'T STAY CLOSED AND YOU FIND THE LOCKING CLIP IS NOT FULLY INSERTED.

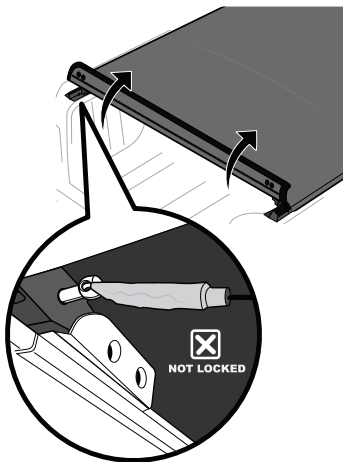

- 16** • IF NEEDED, FOLLOW INSTRUCTIONS IN PAGE 12 TO ADJUST THE TENSION PLATE.

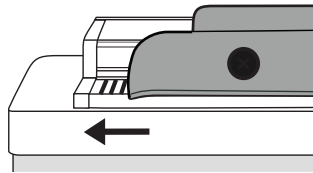

- 17** • MAKE SURE THE LOCKING CLIP ON BOTH SIDES ARE INSERTED INTO THE CHANNEL ON THE SIDE RAILS.

