



TYGER[®]

TYGER ARMOR™

TG-AM2F20118

Parts List

- x1** Driver Side Armor
- x1** Passenger Side Armor
- x10** 8mm Deep Clip Nuts
- x10** 8-1.25mm x 30mm Hex Bolts
- x10** 8-1.25mm x 25mm Hex Bolts
- x10** 8mm x 28mm OD x 3mm Large Flat Washers
- x20** 8mm x 24mm OD x 2mm STD Flat Washers
- x20** 8mm Lock Washers
- x10** 8mm Hex Nuts

Before Installation

READ INSTRUCTIONS CAREFULLY BEFORE STARTING INSTALLATION. REMOVE CONTENTS FROM BOX AND VERIFY ALL PARTS ARE PRESENT. ASSISTANCE IS RECOMMENDED.

Warning

To protect your investment, wax this product after installing. Regular waxing is recommended to add a protective layer over the finish. Do not use any type of polish or wax that may contain abrasives that could damage the finish. Use only mild soap to clean the Side Armor.

Passenger/Right Side Armor Illustrated

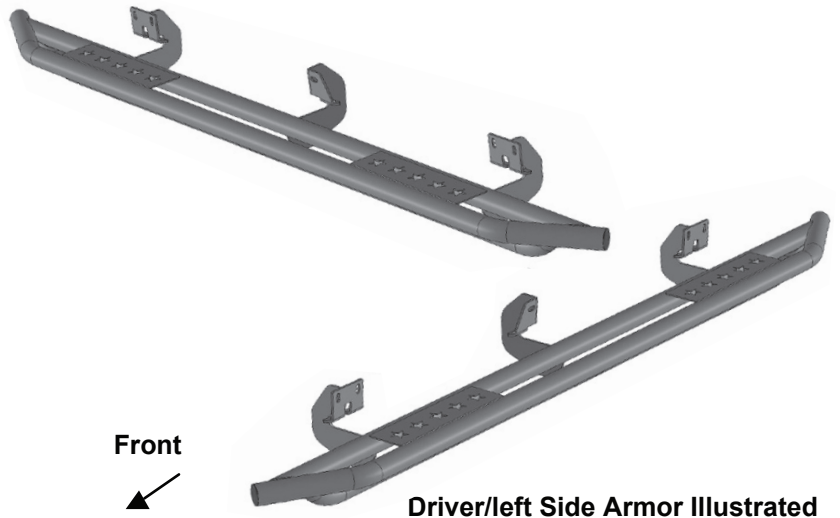

STEP 1

Starting on the passenger side of the vehicle, locate the (2) holes in the bottom of the body panel, (pinch weld). Next locate the rectangular opening and (2) small holes in the inner body panel directly above the holes in the pinch weld, (Figures 1 & 2). NOTE: The holes in the body panel may be covered with sealing tape or insulation.

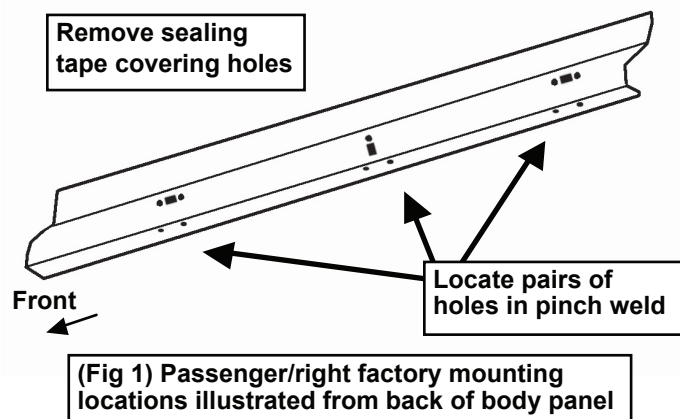



STEP 2

Slide (1) 8mm Clip Nut into the rectangular opening with the nut towards the inside. Line up the threaded nut on the clip with the round hole, (Figure 2). Repeat to install 2nd 8mm Clip Nut in remaining hole location.

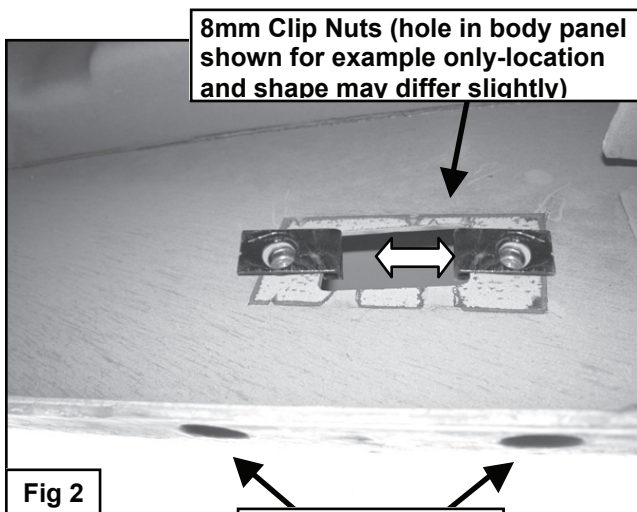

Locate pairs of holes in pinch weld

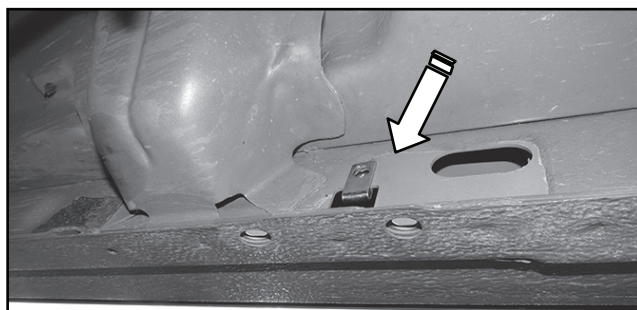

(Fig 3) Passenger/right center mounting location. NOTE: Requires (1) 8mm Clip Nut only (arrow)

STEP 3

Continue along the cab to the center mounting location. Note that the center location only requires (1) 8mm Clip Nut in the upper position, (Figure 3). Repeat Steps 1 & 2 to install the (1) 8mm Clip Nut in the center mounting location only.

STEP 4

Locate the last (2) mounting holes in the pinch weld towards the back of the cab. Repeat Steps 1 & 2 to install the (2) 8mm Clip Nuts.

STEP 5

Select the passenger/right Side Armor. NOTE: Left and right Side Armor assemblies are very similar. Use Figure 4 to properly identify the passenger/right Side Armor assembly.

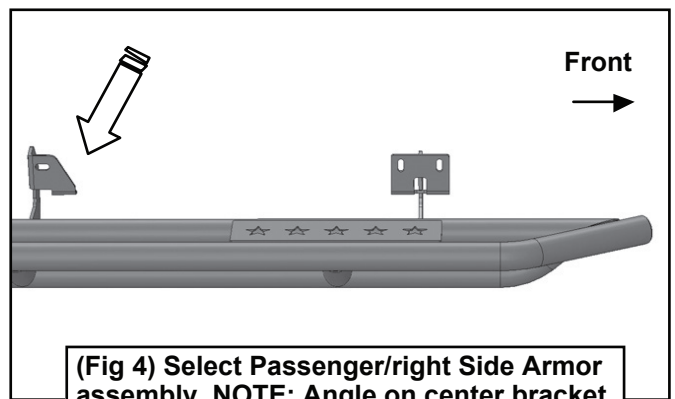

(Fig 4) Select Passenger/right Side Armor assembly. NOTE: Angle on center bracket mounting plate (arrow) faces forward



STEP 6

With assistance, hold the passenger/right Side Armor up in place against the inner body panel. Attach the Side Armor to the (5) Clip Nuts with the included (5) 8mm x 30mm Hex Bolts, (5) 8mm Lock Washers and (5) 8mm x 28mm Large Flat Washers, (Figures 5-8). Leave hardware loose.

(Fig 5) Example of front/rear Bracket installation

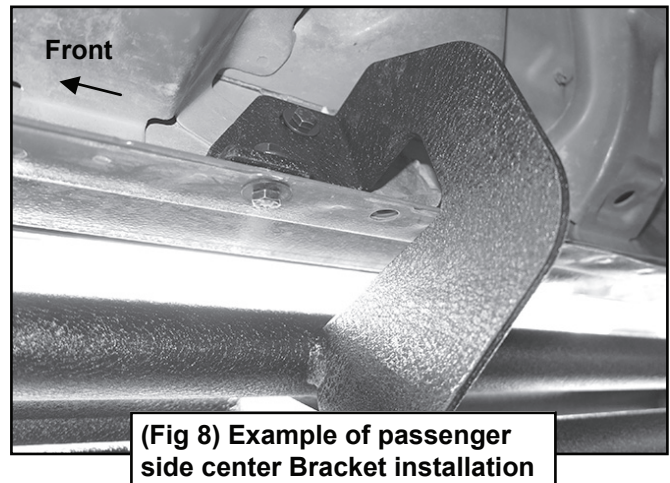
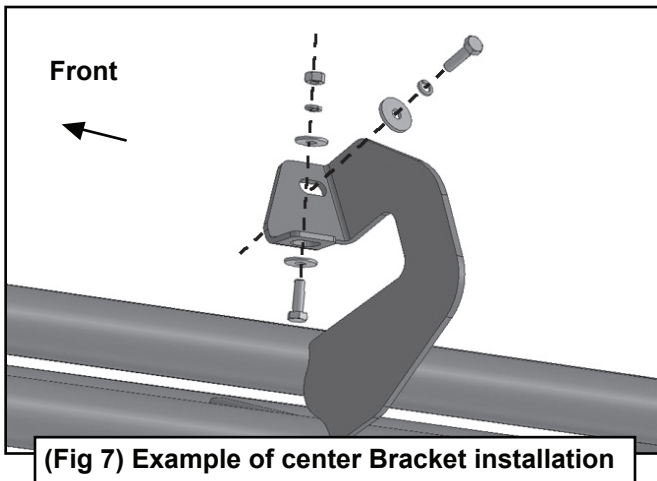
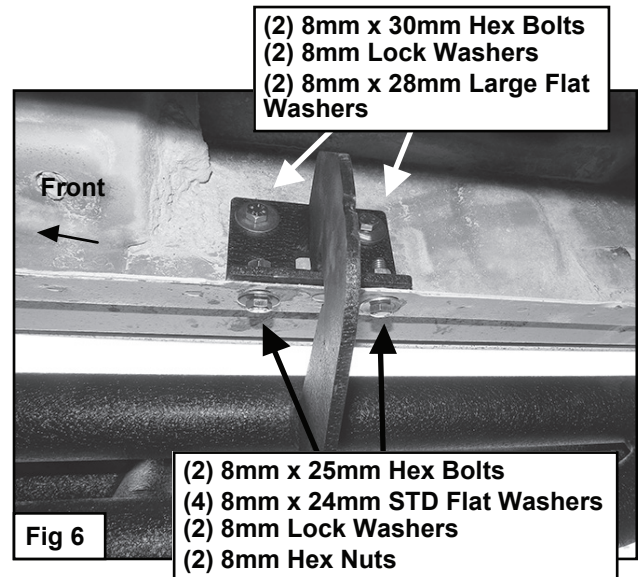
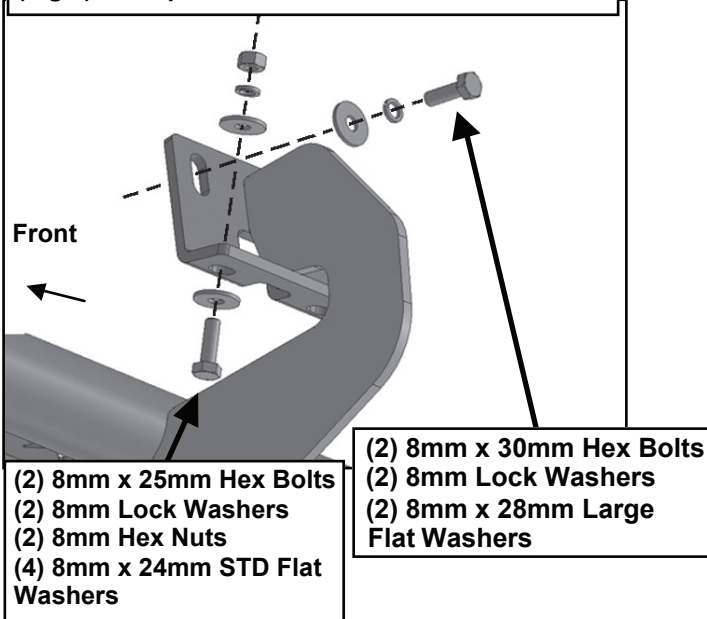



TYGER[®]

STEP 7

Align the bottom holes in the Side Armor with the holes along the pinch weld. Attach the Side Armor to the pinch weld using the included (5) 8mm x 25mm Hex Bolts, (10) 8mm STD Flat Washers, (5) 8mm Lock Washers and (5) 8mm Hex Nuts, (Figures 5-8). **NOTE:** Insert the bolts up from the bottom of the pinch weld and through the Bracket.

STEP 8

Level and adjust the Side Armor and tighten all hardware.

STEP 9

Repeat Steps 1-8 for driver/left Side Armor installation. **NOTE:** Depending on model and year, the brake cable may be run on the inside or outside of the front bracket.

STEP 10

Do periodic inspections to the installation to make sure that all hardware is secure and tight.

