



## STAR ARMOR®

TG-AM2F20358

### BEFORE INSTALLATION

READ INSTRUCTIONS CAREFULLY BEFORE STARTING INSTALLATION. REMOVE CONTENTS FROM BOX AND VERIFY ALL PARTS ARE PRESENT. FAILURE TO IDENTIFY DAMAGE BEFORE INSTALLATION COULD LEAD TO A REJECTION OF ANY CLAIM. IF MISSING PARTS OR ANY DAMAGE FOUND, PLEASE TAKE A PICTURE FOR THE CLAIM PURPOSE. TO FILE YOUR CLAIM, PLEASE VISIT: [WWW.TYGERAUTO.COM/CONTACT](http://WWW.TYGERAUTO.COM/CONTACT)

### TORQUE VALUES

Fastener Size	Class 8.8 Torque (ft-lbs)	Class 10.9 Torque (ft-lbs)
6mm	6-7	6-7
8mm	15-16	22-23
10mm	31-32	44-45
12mm	54-55	78-79
14mm	87-88	125-126

## Parts List

- x1 Driver/Left Tyger Armor
- x1 Passenger/Right Tyger Armor
- x12 10-1.5mm x 25mm Hex bolts
- x12 10mm Lock Washers
- x12 10mm x 27mm OD x 3mm Flat Washers

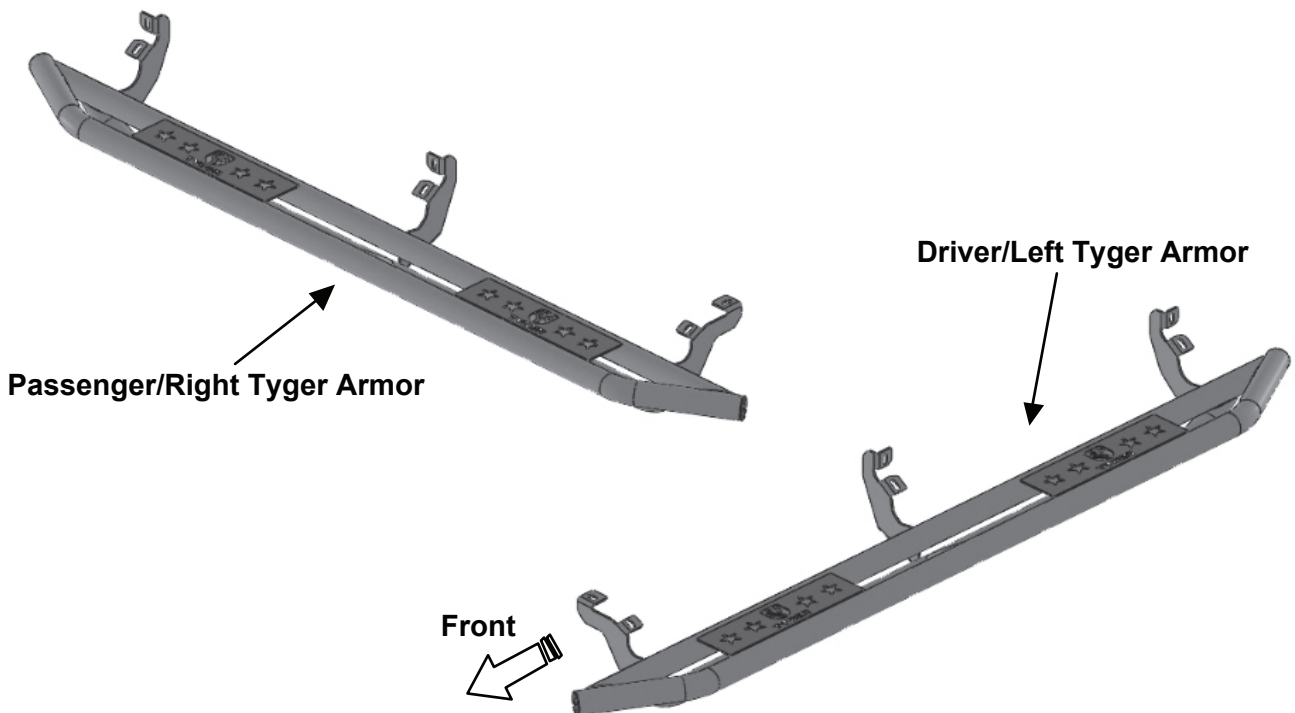



## STEP 1

REMOVE CONTENTS FROM BOX. VERIFY ALL PARTS ARE PRESENT. READ INSTRUCTIONS CAREFULLY BEFORE STARTING INSTALLATION.

## STEP 2

Starting from underneath the Passenger/Right body panel, locate the mounting locations and the threaded holes in the body panel, (Figs 1-3). Remove the plastic plugs covering the holes.

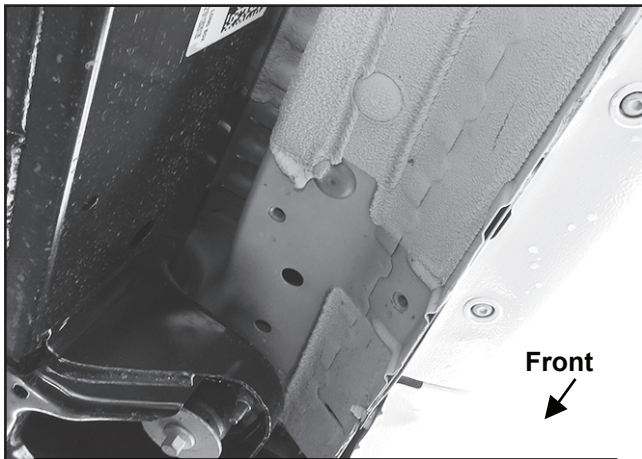

(Fig 1) Passenger/Right front mounting location



(Fig 2) Passenger/Right center mounting location



(Fig 3) Passenger/Right rear mounting location

## STEP 3

Select the Passenger/Right Tyger Armor. Attach the Tyger Armor to the body panel with (6) 10mm x 25mm Hex Bolts, (6) 10mm Lock Washers and (6) 10mm Flat Washers, (Figs 4-5). Do not tighten hardware at this time.

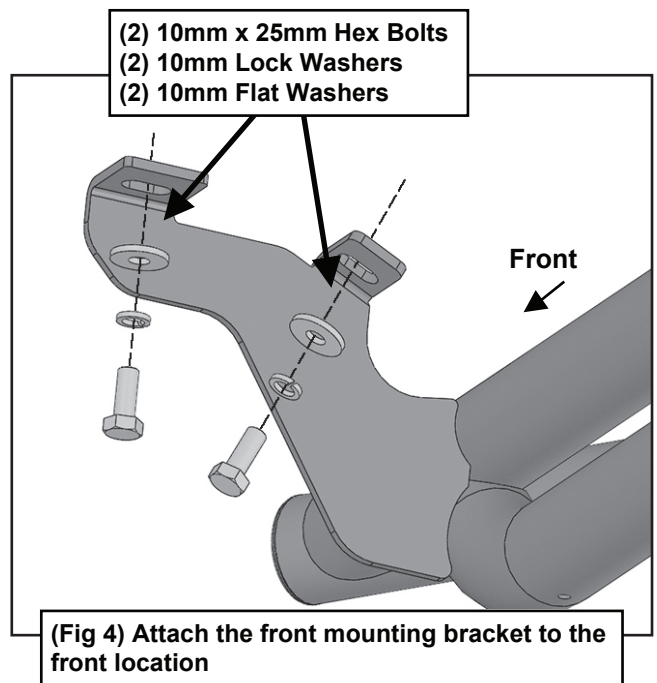

(Fig 4) Attach the front mounting bracket to the front location

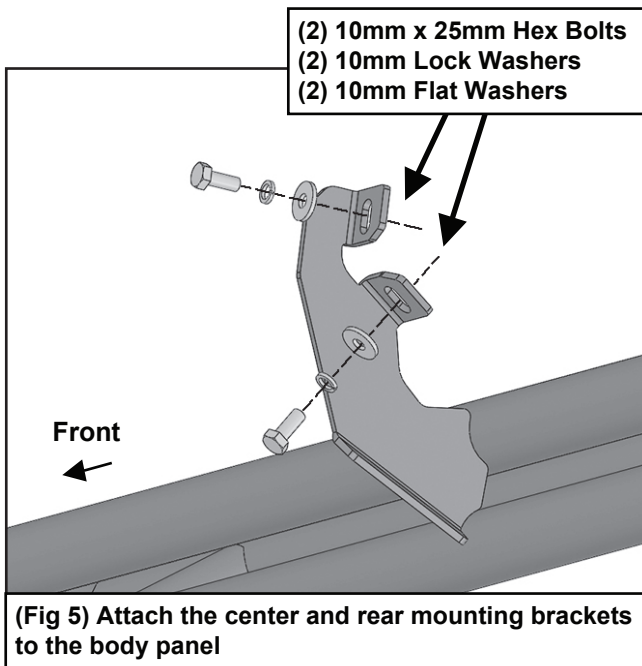

## STEP 4

Level and adjust the Tyger Armor and tighten all hardware.

## STEP 5

Repeat Steps 2-4 to attach the Driver/Left Tyger Armor.

## STEP 6

Do periodic inspections to the installation to make sure that all hardware is secure and tight.