

# TYGER ACCESS

TG-AS2J24007

Scan to Download the Latest Digital Version



## BEFORE INSTALLATION

READ INSTRUCTIONS CAREFULLY BEFORE STARTING INSTALLATION. REMOVE CONTENTS FROM BOX AND VERIFY ALL PARTS ARE PRESENT. FAILURE TO IDENTIFY DAMAGE BEFORE INSTALLATION COULD LEAD TO A REJECTION OF ANY CLAIM. IF MISSING PARTS OR ANY DAMAGE FOUND, PLEASE TAKE A PICTURE FOR THE CLAIM PURPOSE. TO FILE YOUR CLAIM, PLEASE VISIT:

[WWW.TYGERAUTO.COM/CONTACT](http://WWW.TYGERAUTO.COM/CONTACT)

## TORQUE VALUES

Fastener Size	Class 8.8 Torque (ft-lbs)	Class 10.9 Torque (ft-lbs)
6mm	6-7	6-7
8mm	15-16	22-23
10mm	31-32	44-45
12mm	54-55	78-79
14mm	87-88	125-126

- |  |  |   |
|--|--|---|
| <b>x1</b> Driver/Left Tyger Access                     | <b>x1</b> Driver/Left Front Support Bracket [G]                | <b>x24</b> 6mm x 22mm x 2mm Flat Washers    |
| <b>x1</b> Passenger/Right Tyger Access                 | <b>x1</b> Passenger/Right Front Support Bracket [I]            | <b>x12</b> 10mm x 24mm x 2.2mm Flat Washers |
| <b>x1</b> Driver/Left Front Mounting Bracket [A]       | <b>x2</b> Driver/Left Central and Rear Support Bracket [H]     | <b>x6</b> 8mm x 28mm x 3mm Flat Washers     |
| <b>x1</b> Passenger/Right Front Mounting Bracket [D]   | <b>x2</b> Passenger/Right Central and Rear Support Bracket [J] | <b>x12</b> 6mm Nylon Lock Nuts              |
| <b>x1</b> Driver/Left Central Mounting Bracket [B]     | <b>x12</b> 6mm x 1.0mm x 25mm Hex Bolts                        | <b>x6</b> 10mm Nylon Lock Nuts              |
| <b>x1</b> Passenger/Right Central Mounting Bracket [E] | <b>x6</b> 10mm x 1.5mm x 30mm Hex Bolts                        | <b>x6</b> 8mm Lock Washers                  |
| <b>x1</b> Driver/Left Rear Mounting Bracket [C]        | <b>x6</b> 8mm x 1.25mm x 35mm Hex Bolts                        |   |
| <b>x1</b> Passenger/Right Rear Mounting Bracket [F]    | <b>x12</b> 8mm x 1.25mm x 25mm Hex Combo Bolts                 |   |

## Parts List

### Top View

**ATTENTION:** Refer to **D** and **P** labelling on the side of the tubes to determine Driver and Passenger TYGER Access

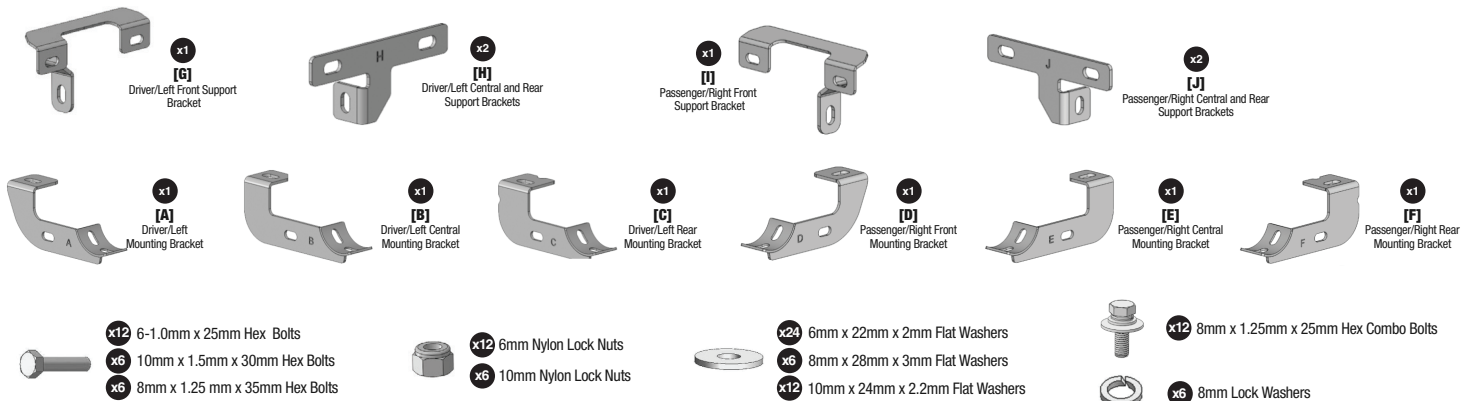
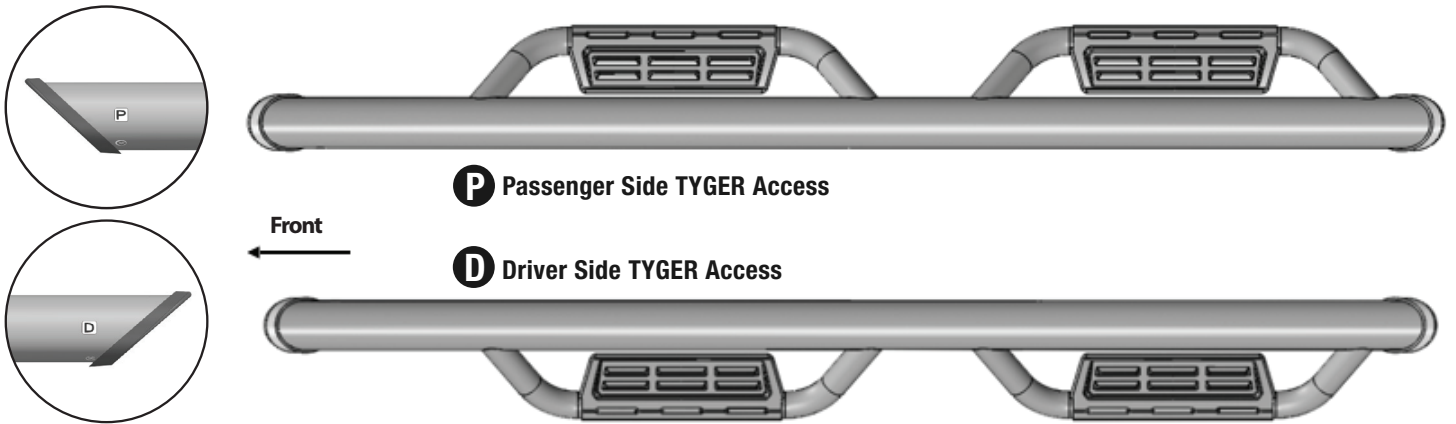

Reference the letters printed on the brackets to determine mounting locations

**Top View**

**P** Passenger Side TYGER Access

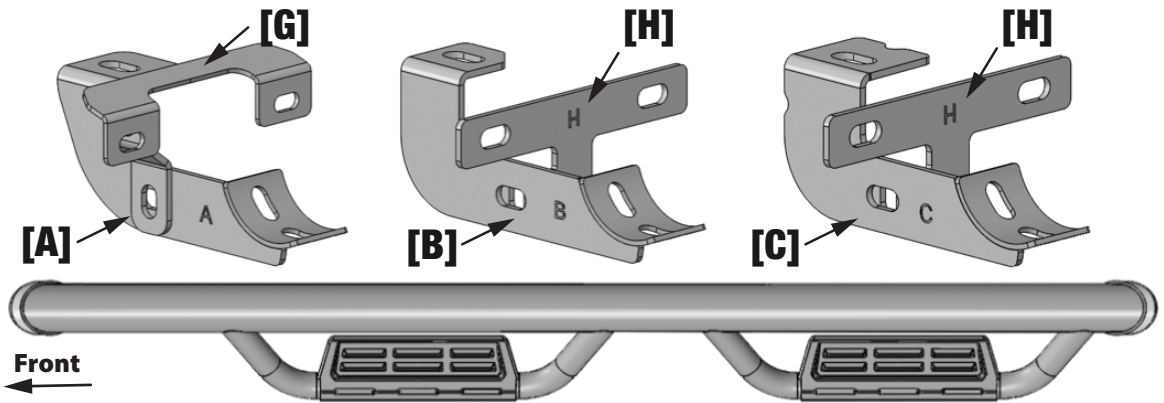
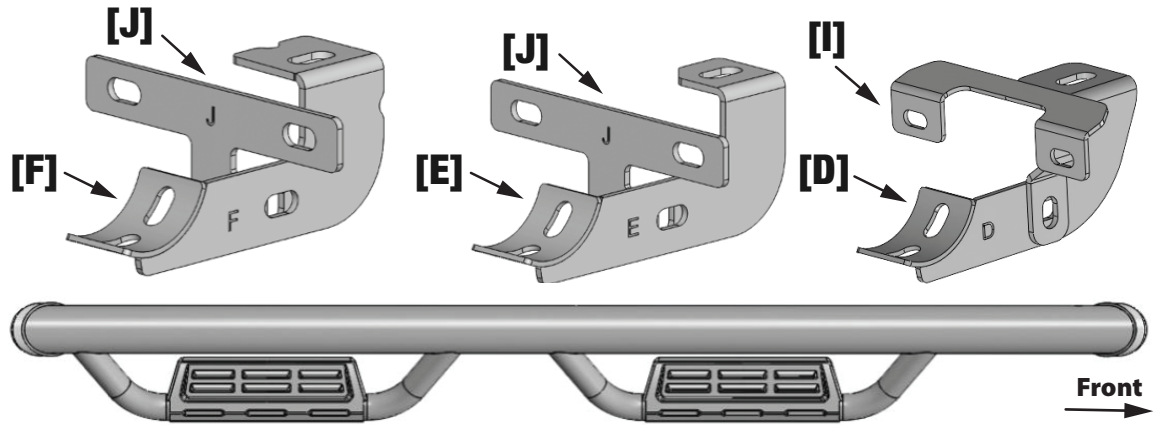

**D** Driver Side TYGER Access

**Bottom View**

**P** Passenger Side TYGER Access

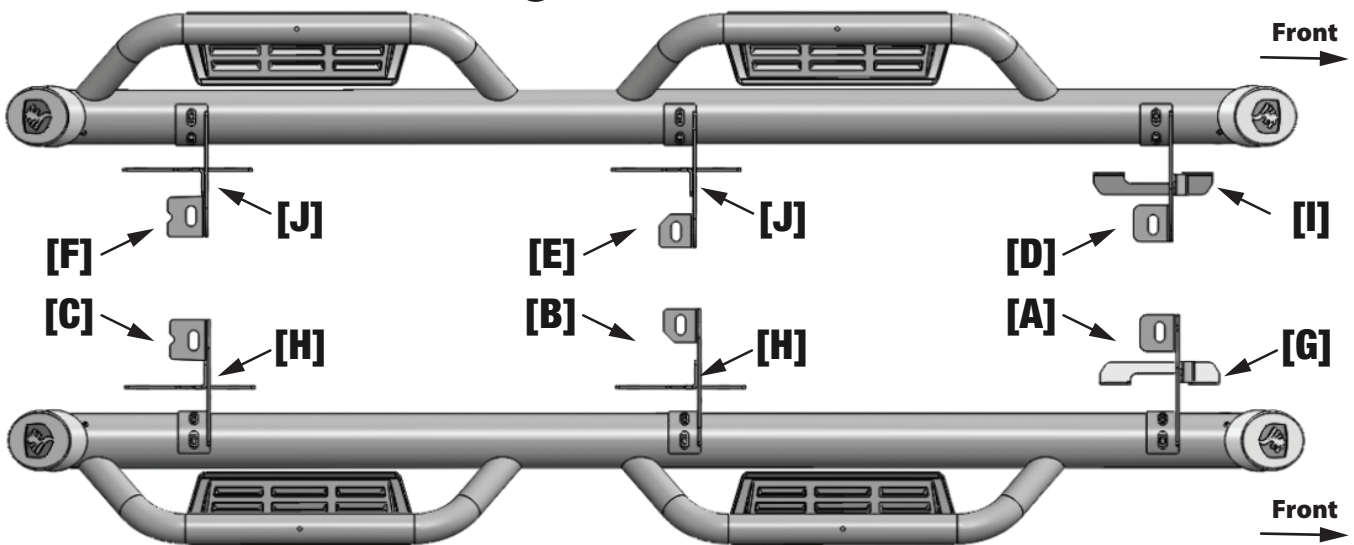

**D** Driver Side TYGER Access

## TOOLS REQUIRED

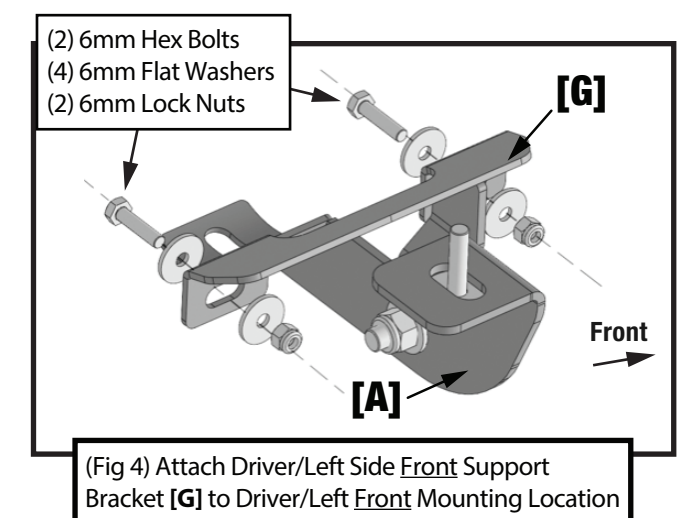
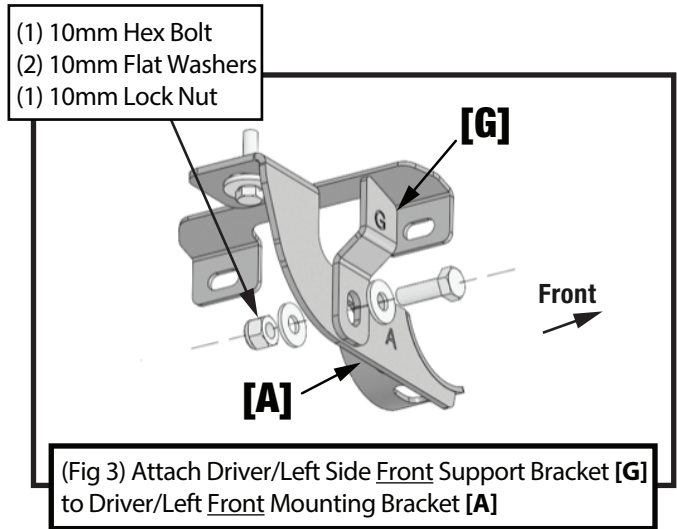
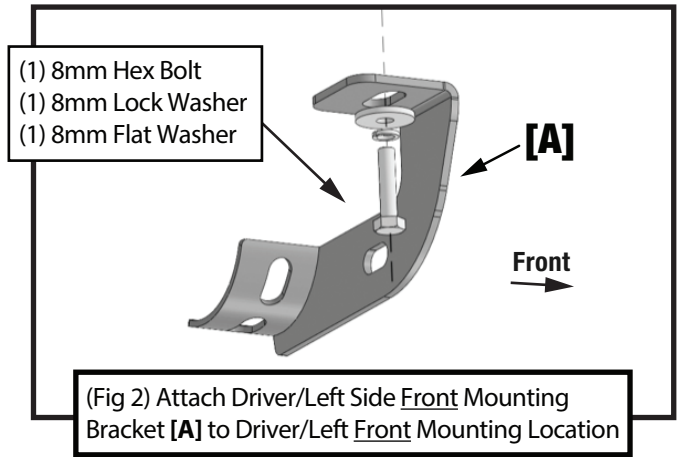
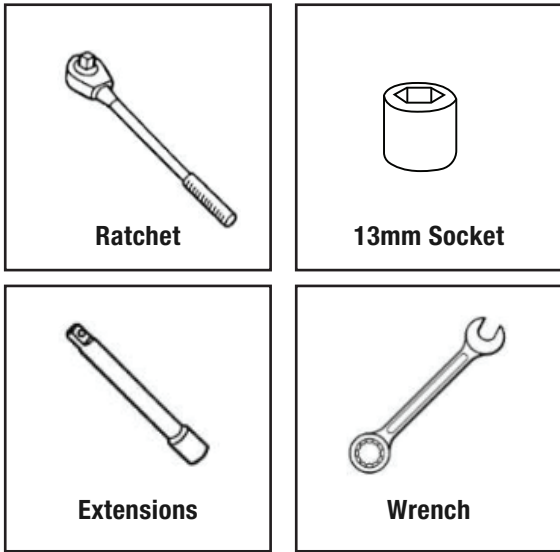

## STEP 1 MOUNTING BRACKETS

Follow (Fig 1 – 15) to attach the brackets to the Driver Side. Ensure hardware is hand tightened at this point.

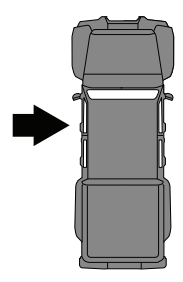

### Driver-side Front Mounting Area

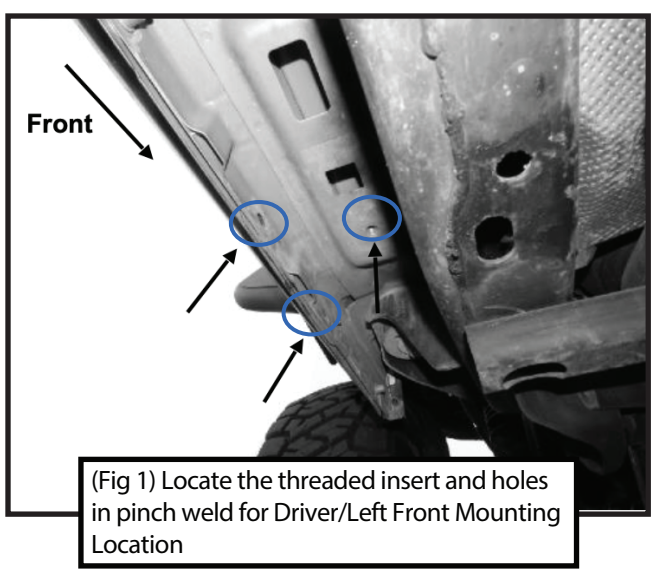

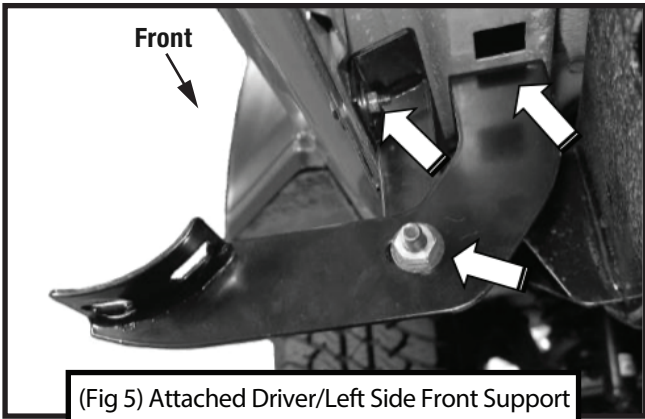

(Fig 5) Attached Driver/Left Side Front Support Bracket [G] and Driver/Left Front Bracket [A]

**Driver-side Center Mounting Area**

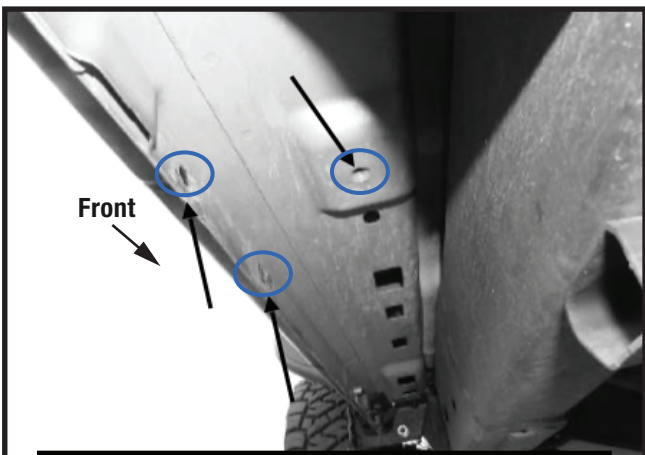

(Fig 6) Locate the threaded insert and holes in pinch weld for Driver/Left Center Mounting Location

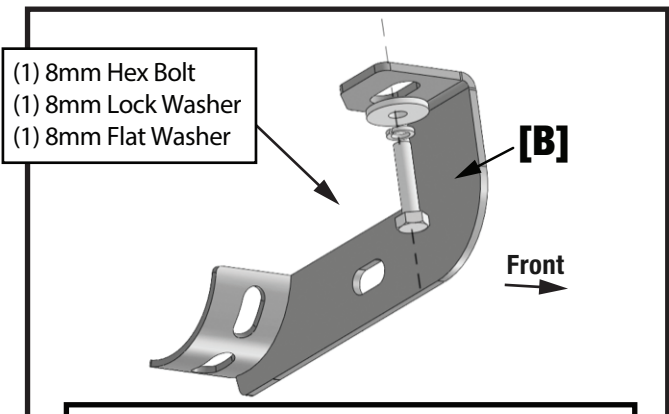

(Fig 7) Attach Driver/Left Side Center Mounting Bracket [B] to Driver/Left Center Mounting Location

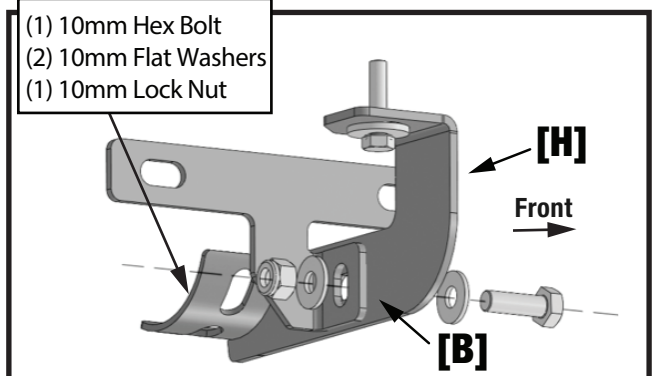

(Fig 8) Attach Driver/Left Side Center & Rear Support Bracket [H] to Driver/Left Center Mounting Bracket [B]

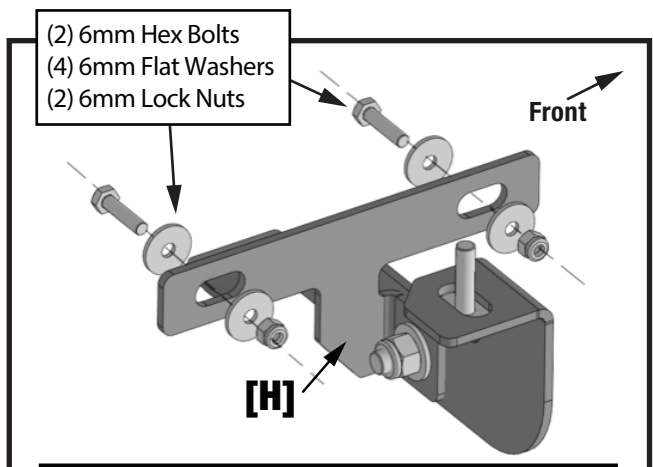

(Fig 9) Attach Driver/Left Side Center & Rear Support Bracket [H] to Driver/Left Center Mounting Location

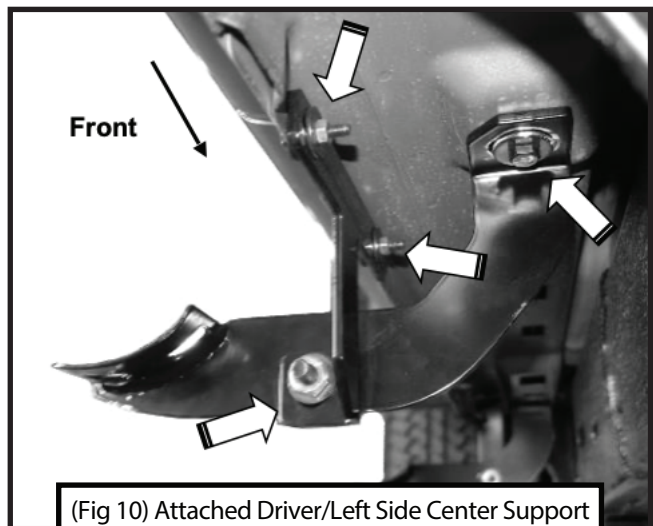

(Fig 10) Attached Driver/Left Side Center Support Bracket [H] and Driver/Left Center Bracket [B]

**Driver-side Rear Mounting Area**

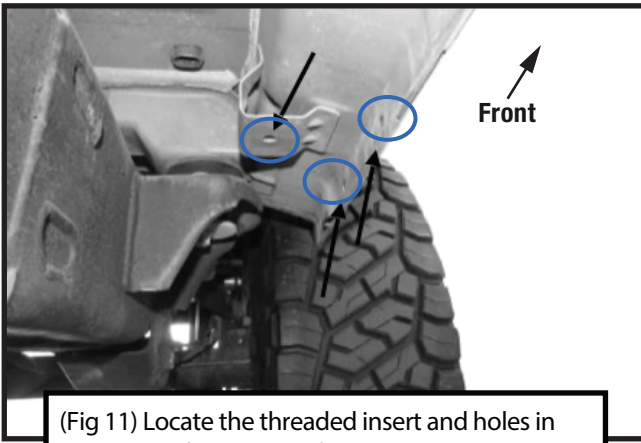

(Fig 11) Locate the threaded insert and holes in pinch weld for Driver/Left Rear Mounting Location

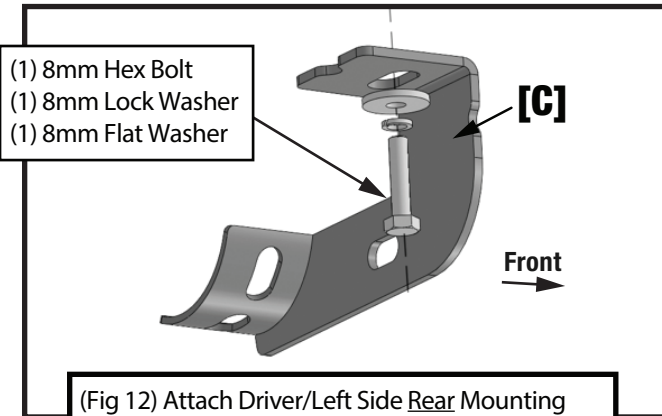

(Fig 12) Attach Driver/Left Side Rear Mounting Bracket [C] to Driver/Left Rear Mounting Location

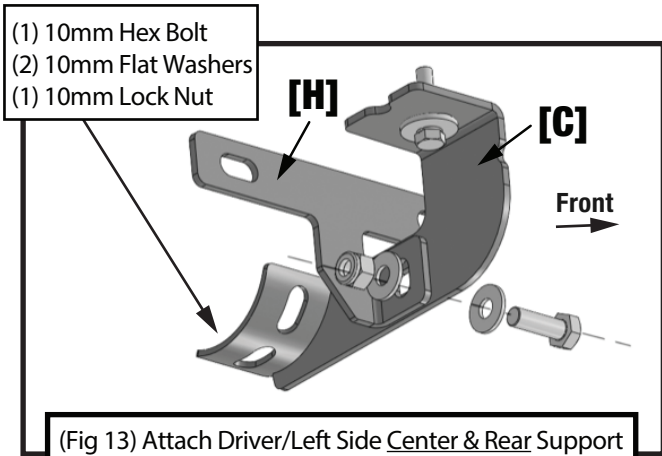

(Fig 13) Attach Driver/Left Side Center & Rear Support Bracket [H] to Driver/Left Rear Mounting Bracket [C]

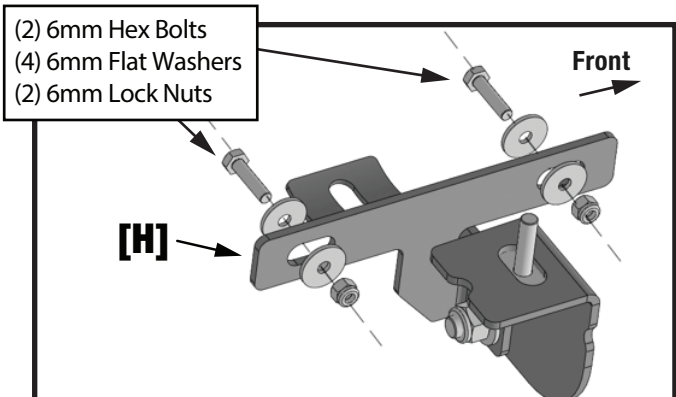

(Fig 14) Attach Driver/Left Side Center & Rear Support Bracket [H] to Driver/Left Rear Mounting Location

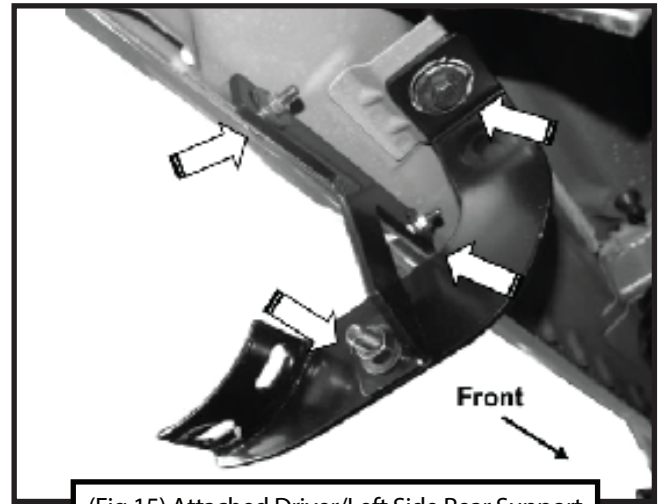

(Fig 15) Attached Driver/Left Side Rear Support Bracket [H] and Driver/Left Rear Bracket [C]

## STEP 2 MOUNTING RUNNING BOARD

Follow (Fig 16-17) to install the Access Drop Step on the Driver/Left Side. Ensure all hardware is hand tightened at this point.

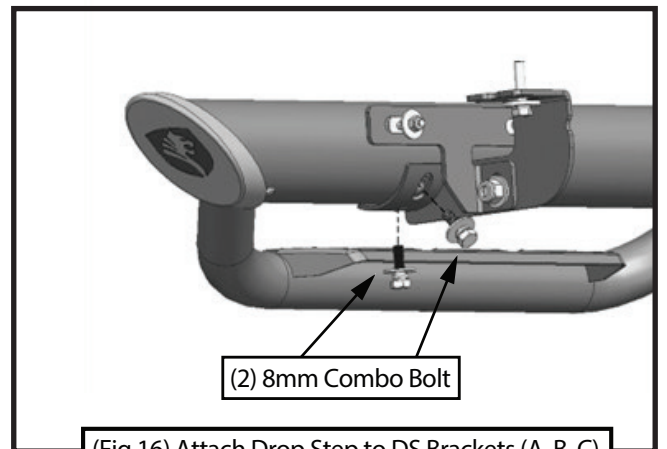

(Fig 16) Attach Drop Step to DS Brackets (A, B, C)

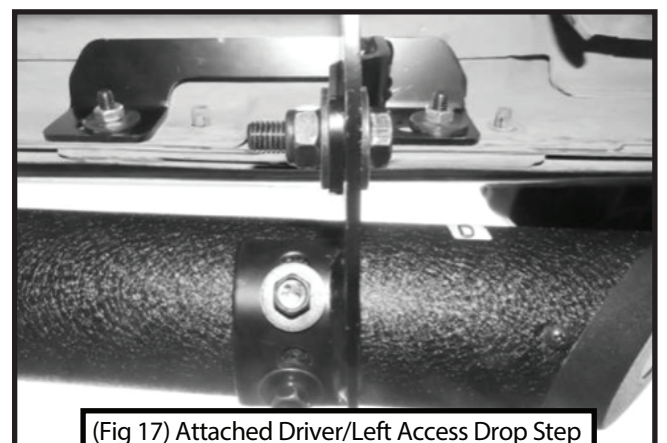

(Fig 17) Attached Driver/Left Access Drop Step to Driver/Left Mounting Brackets [A],[B],[C]

## STEP 3 PASSENGER SIDE

Repeat **STEPS 1-2** for passenger side installation.  
 Use Front Mounting Bracket **[D]** instead of **[A]**;  
 Use Center Mounting Bracket **[E]** instead of **[B]**;  
 Use Rear Mounting Bracket **[F]** instead of **[C]**;  
 Use Front Support Bracket **[I]** instead of **[G]**;  
 Use Center & Rear Support Brackets **[J]** instead of **[H]**.

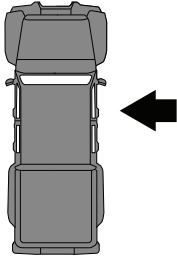

## STEP 4 COMPLETION

Ensure Tyger Access Drop Step is level and straightened, then tighten all fasteners. Installation is complete. Perform periodic inspections to the installation to make sure that all hardware is secure and tight.

