



TYGER®

TYGER BLADE

TG-BL3T7408

CONTACT US:

1-866-340-3038

PHONE



LIVE CHAT

BEFORE INSTALLATION

READ INSTRUCTIONS CAREFULLY BEFORE STARTING INSTALLATION. REMOVE CONTENTS FROM BOX AND VERIFY ALL PARTS ARE PRESENT. FAILURE TO IDENTIFY DAMAGE BEFORE INSTALLATION COULD LEAD TO A REJECTION OF ANY CLAIM. IF MISSING PARTS OR ANY DAMAGE FOUND, PLEASE TAKE A PICTURE FOR THE CLAIM PURPOSE. TO FILE YOUR CLAIM, PLEASE VISIT:

WWW.TYGERAUTO.COM/CONTACT

TORQUE VALUES

Fastener Size	Class 8.8 Torque (ft-lbs)	Class 10.9 Torque (ft-lbs)
6mm	6-7	6-7
8mm	15-16	22-23
10mm	31-32	44-45
12mm	54-55	78-79
14mm	87-88	125-126

- x2 TYGER Blade Running Boards (78in)
- x12 8mm Nylon Lock Nuts
- x2 Front Mounting Brackets [A]
- x12 8-1.25mm x 30mm Hex Bolts
- x4 Center and Rear Mounting Brackets [B]
- x12 8mm Lock Washers
- x6 8mm Double Bolt Plates
- x24 8mm x 24mm x 2mm Flat Washers

Parts List

Top View

Passenger Side TYGER Blade



Driver Side TYGER Blade



x2

[A]

Front Mounting Brackets



x4

[B]

Center & Rear Mounting Brackets



x12 8mm Nylon Lock Nuts



x24 8mm x 24mm x 2mm Flat Washers



x6 8mm Double Bolt Plates



x12 8-1.25mm x 30mm Hex Bolts



x12 8mm Lock Washers

Reference the letters printed on the brackets to determine mounting locations

Top View

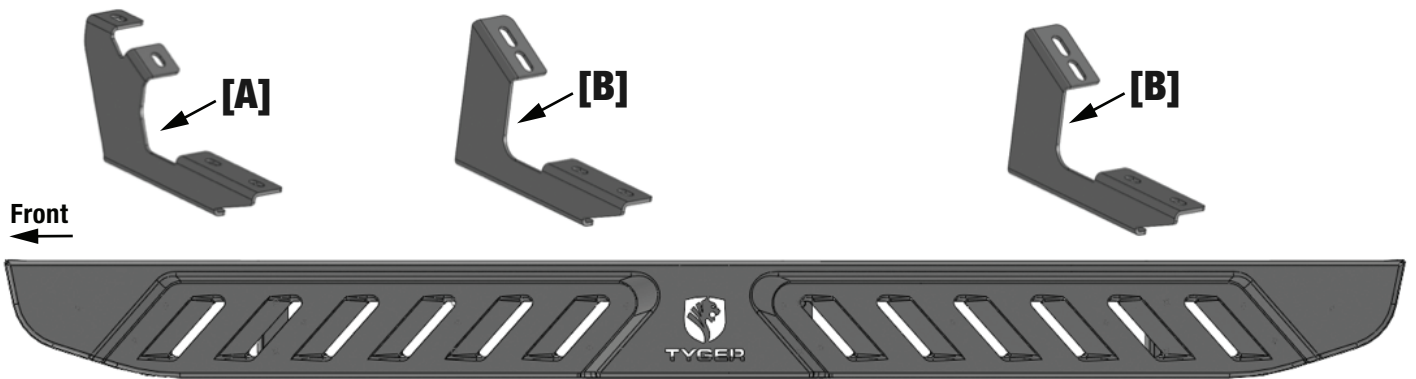

Driver Side TYGER Blade

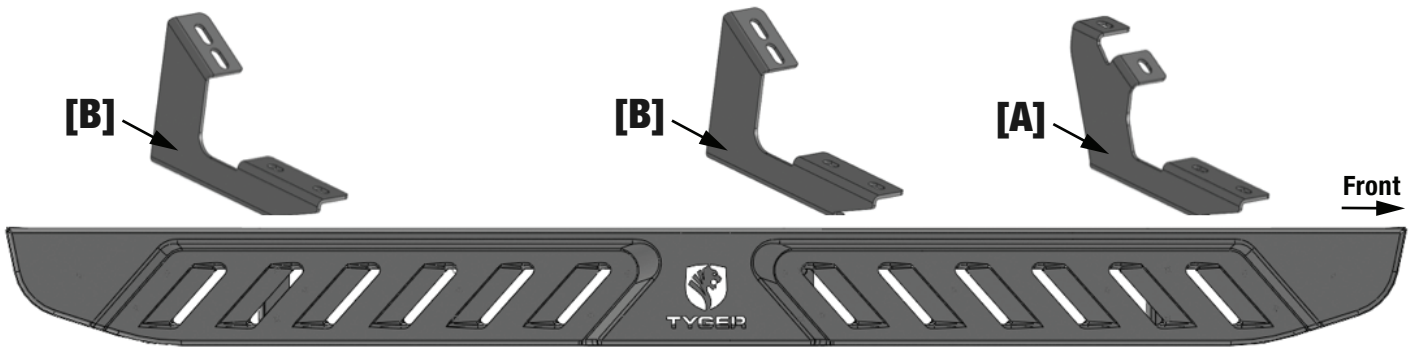

Passenger Side TYGER Blade

Bottom View

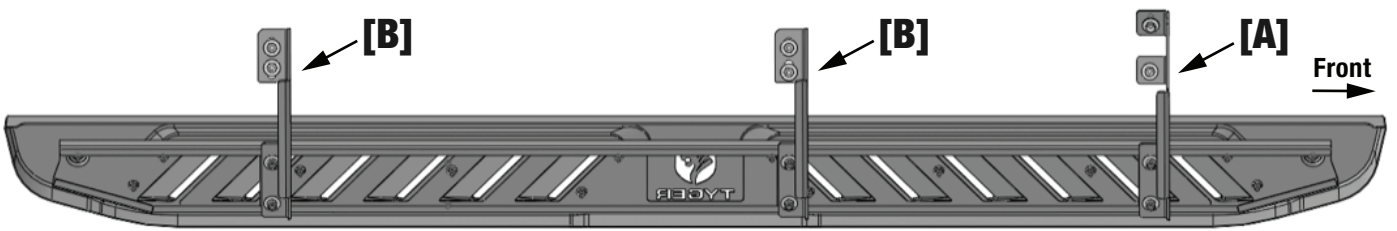

Driver Side TYGER Blade

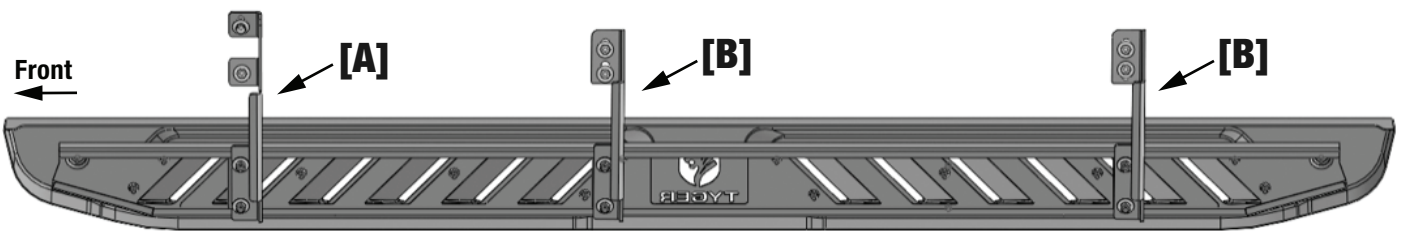

Passenger Side TYGER Blade

TOOLS REQUIRED

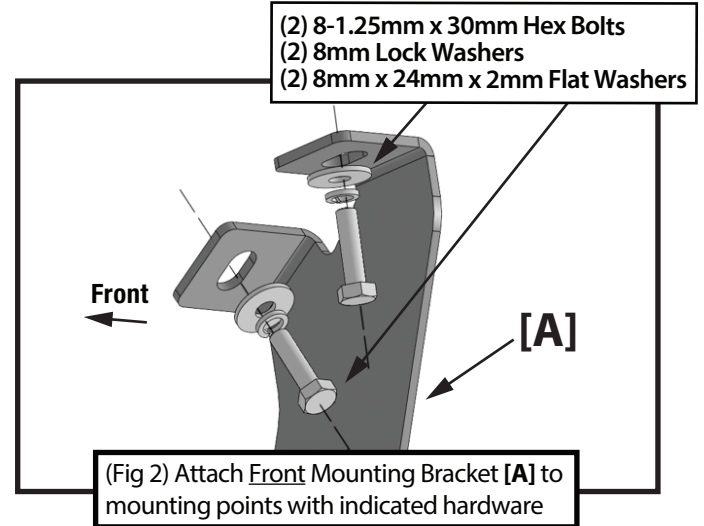
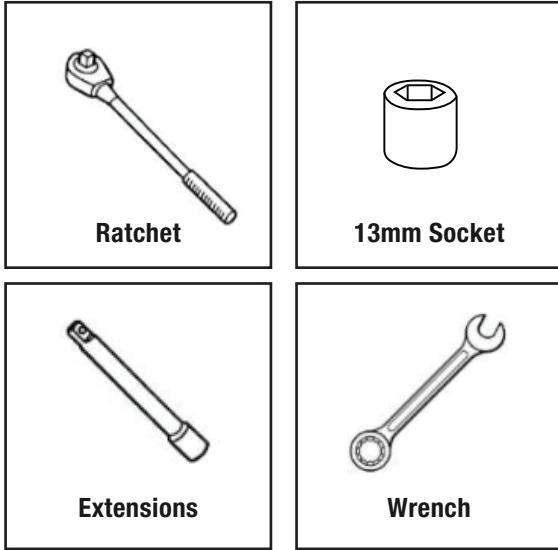

STEP 1 MOUNTING BRACKETS

Follow (Fig 1 – 9) to attach the brackets to the Passenger/Right Side. DO NOT tighten fully at this time.

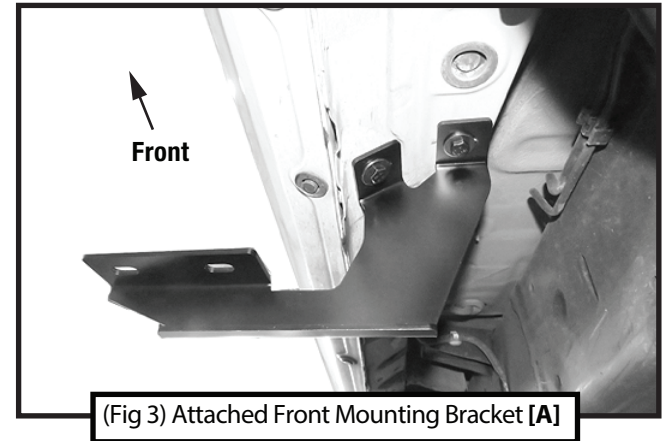
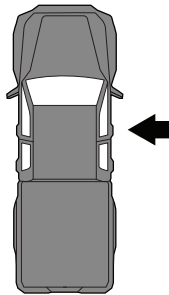

Passenger Front Mounting Areas

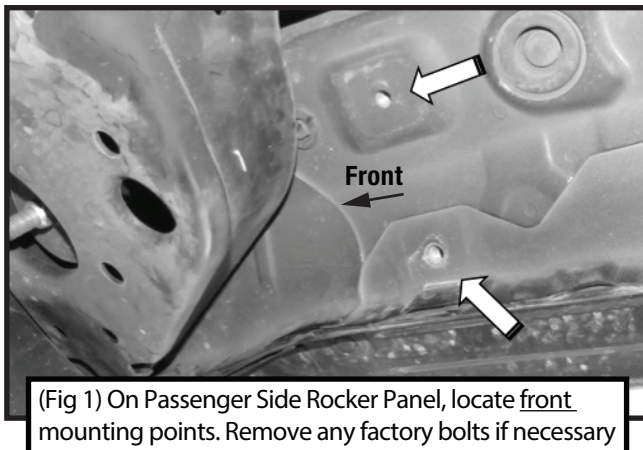

Passenger Center Mounting Areas

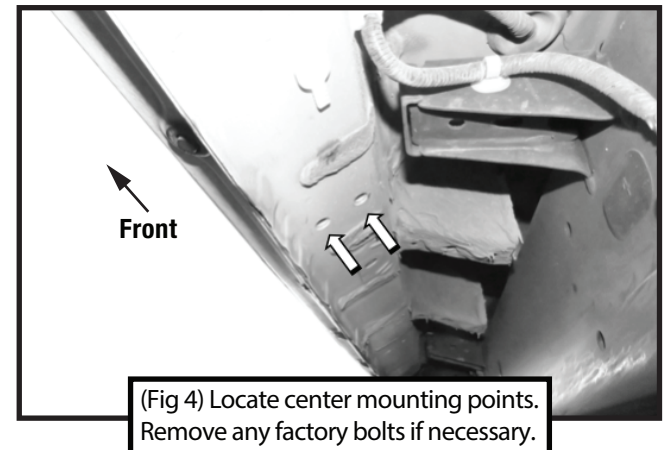

(2) 8-1.25mm x 30mm Hex Bolts
 (2) 8mm Lock Washers
 (2) 8mm x 24mm x 2mm Flat Washers

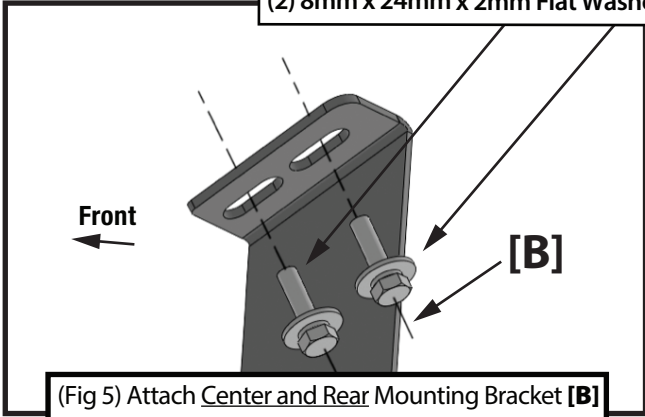

(Fig 5) Attach Center and Rear Mounting Bracket [B] to mounting points with indicated hardware

(2) 8-1.25mm x 30mm Hex Bolts
 (2) 8mm Lock Washers
 (2) 8mm x 24mm x 2mm Flat Washers

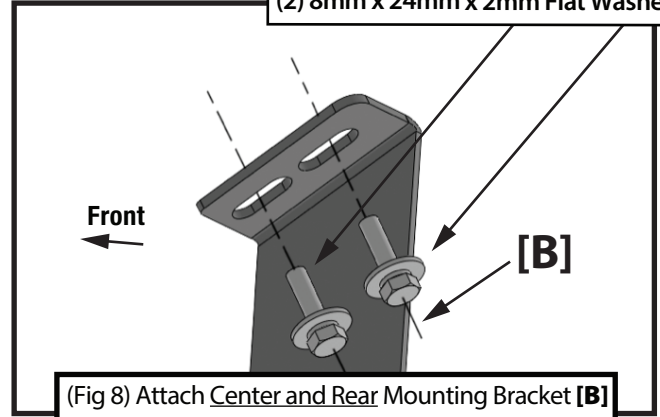

(Fig 8) Attach Center and Rear Mounting Bracket [B] to mounting points with indicated hardware

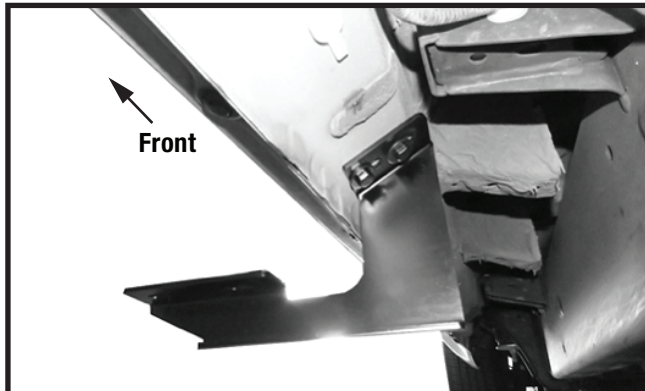

(Fig 6) Attached Center and Rear Mounting Bracket [B]

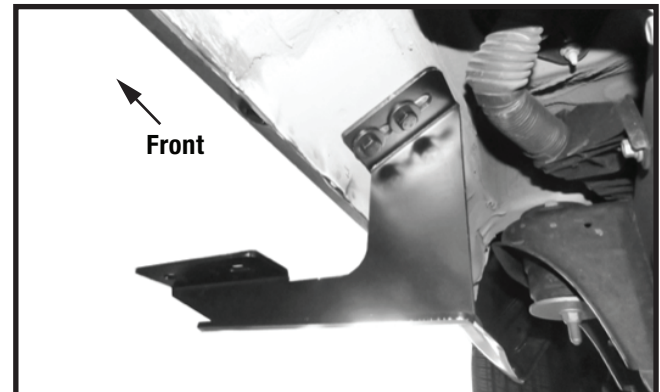

(Fig 9) Attached Center and Rear Mounting Bracket [B]



Passenger Rear Mounting Areas

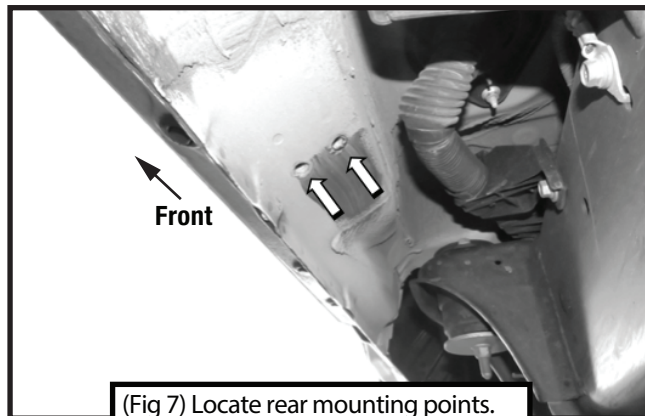

(Fig 7) Locate rear mounting points. Remove any factory bolts if necessary.

STEP 2 MOUNTING RUNNING BOARD

Follow (Fig 10-11) to install the Running Board on the Passenger/Right.

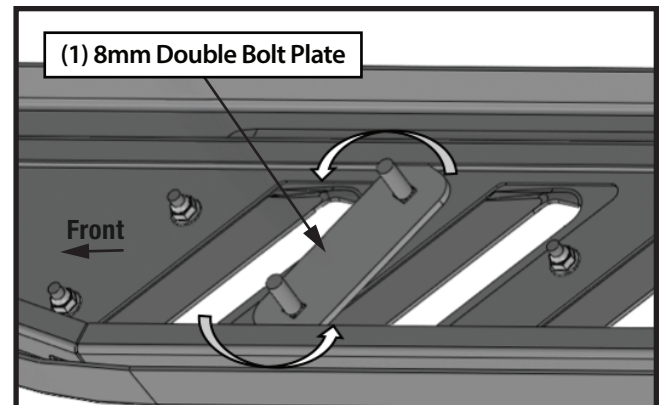

(Fig 10) Insert Double Bolt Plate into Tyger Blade Channels.

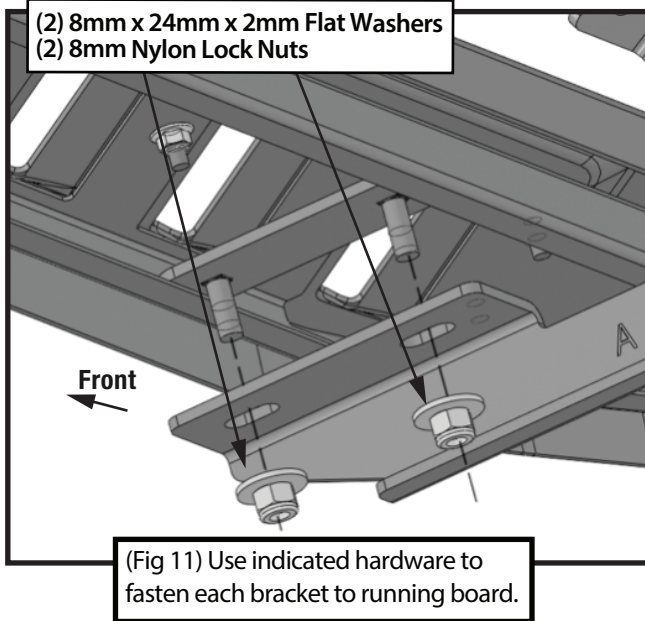

STEP 3 DRIVER SIDE

Repeat **STEPS 1-2** to install mounting brackets to the 3 mounting locations at Driver/Left side.

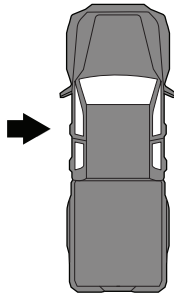

STEP 4 COMPLETION

Ensure running boards are leveled with vehicle and ground, then **completely tighten all hardware**. Installation is complete. Do periodic inspections to the installation to make sure that all hardware is secure and tight.