



TYGER FURY STEPS

TG-FS2T20068

BEFORE INSTALLATION

READ INSTRUCTIONS CAREFULLY BEFORE STARTING INSTALLATION. REMOVE CONTENTS FROM BOX AND VERIFY ALL PARTS ARE PRESENT. FAILURE TO IDENTIFY DAMAGE BEFORE INSTALLATION COULD LEAD TO A REJECTION OF ANY CLAIM. IF MISSING PARTS OR ANY DAMAGE FOUND, PLEASE TAKE A PICTURE FOR THE CLAIM PURPOSE. TO FILE YOUR CLAIM, PLEASE VISIT: WWW.TYGERAUTO.COM/CONTACT

TORQUE VALUES

Fastener Size	Class 8.8 Torque (ft-lbs)	Class 10.9 Torque (ft-lbs)
6mm	6-7	6-7
8mm	15-16	22-23
10mm	31-32	44-45
12mm	54-55	78-79
14mm	87-88	125-126

Parts List

- x1 Driver/Left TYGER Fury Steps Running Board
- x1 Passenger/Right TYGER Fury Steps Running Board
- x1 Driver/Left Front Mounting Bracket
- x1 Passenger/Right Front Mounting Bracket
- x1 Driver/Left Center/Mounting Bracket
- x1 Passenger/Right Center Mounting Bracket
- x1 Driver/Left Rear Mounting Bracket
- x1 Passenger/Right Rear Mounting Bracket
- x12 8mm x 1.25mm x 25mm Combo Hex Bolts
- x12 8mm x 1.25mm x 30mm Hex Bolts
- x12 8mm Lock Washers
- x12 8mm x 24mm OD x 2mm Flat Washers

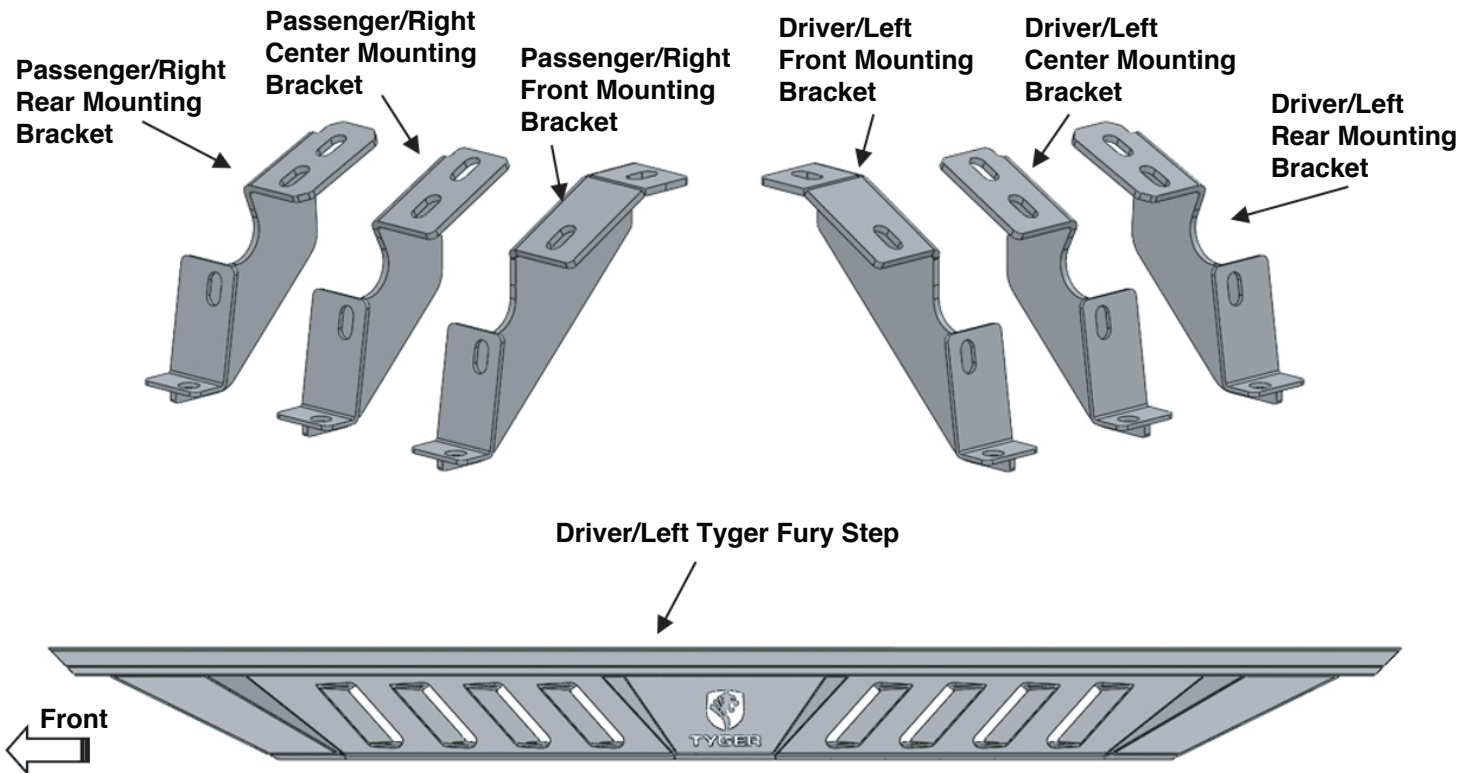



PROCEDURE:

REMOVE CONTENTS FROM BOX. VERIFY ALL PARTS ARE PRESENT. READ INSTRUCTIONS CAREFULLY. USE ILLUSTRATION TO IDENTIFY BRACKETS AND RUNNING BOARDS.

STEP 1

Starting on the Driver/Left front of the vehicle, remove the plastic plugs or hex bolts covering the (2) threaded holes in the floor panel (Fig 1).

Remove plastic plugs or factory hex bolts (if equipped)

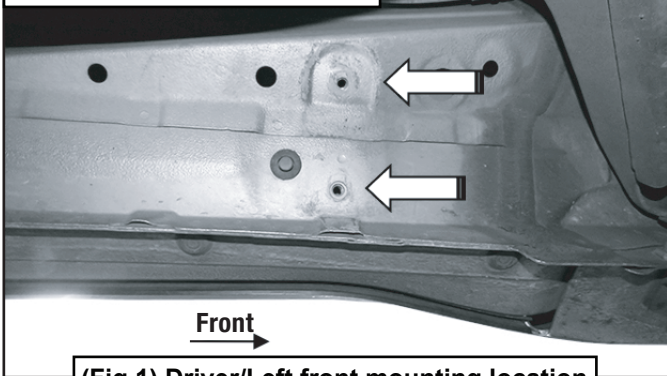

(Fig 1) Driver/Left front mounting location

STEP 2

Select Driver/Left Front Mounting Bracket (Fig 2). Attach the Bracket to the panel with (2) 8mm Hex Bolts, (2) 8mm Lock Washers and (2) 8mm Flat Washers (Fig 2). DO NOT tighten hardware.

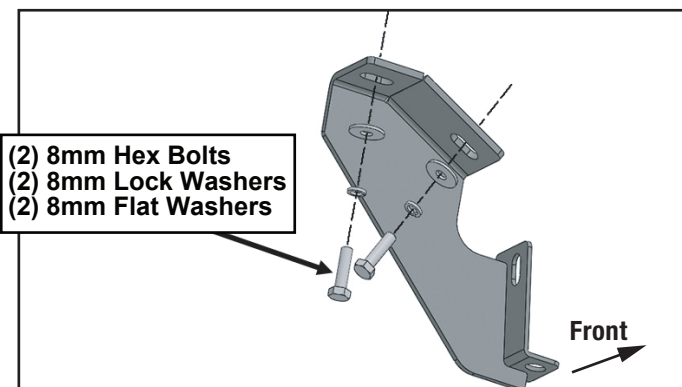

(Fig 2) Attach Driver/Left Front Mounting Bracket to the floor panel

STEP 3

Next, move to the second mounting location (Fig 3). Select (1) Driver/Left Center Mounting Bracket. The Center and Rear Mounting Brackets are similar but unique. The Center Mounting bracket has a notch in the back of the Bracket (Fig 4). Repeat STEP 2 to attach the Bracket to the floor panel (Fig 4).

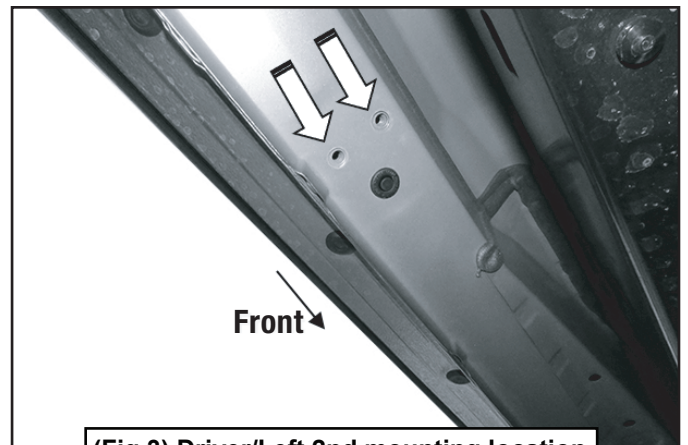

(Fig 3) Driver/Left 2nd mounting location

Center Brackets have a notch in the back of the bracket

(2) 8mm Hex Bolts
(2) 8mm Lock Washers
(2) 8mm Flat Washers

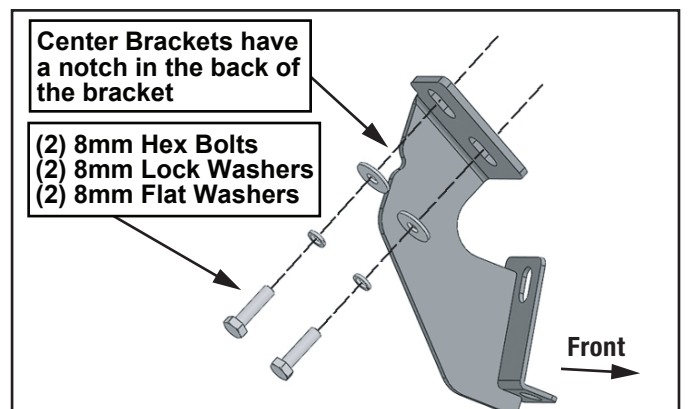

(Fig 4) Attach Driver/Left Center Mounting Bracket to the floor panel



STEP 4

Continue to the rear mounting location (Fig 5). Repeat **STEP 3** to attach (1) Driver/Left Rear Mounting Bracket to the floor panel.

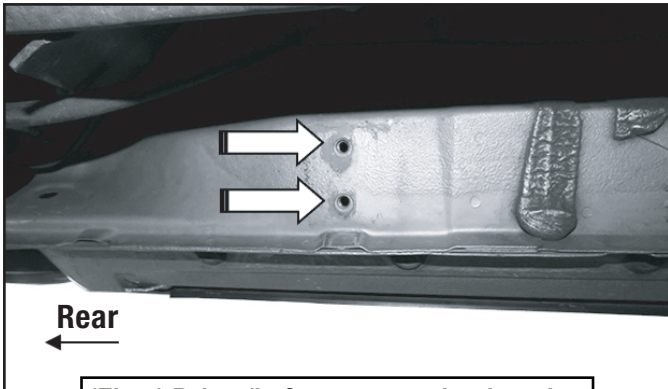

STEP 6

Level and adjust the Tyger Fury Step and tighten all hardware.

STEP 7

Repeat **STEPS 1-6** to attach the Passenger/Right Tyger Fury Step.

STEP 8

Do periodic inspections to the installation to make sure that all hardware is secure and tight.

STEP 5

Select the Driver/Left Tyger Fury Step. Attach the Step to the Mounting Brackets with (6) 8mm Combo Bolts (Fig 6). **DO NOT** tighten hardware.

