



TYGER ARMOR™

TG-JA2J2288B

BEFORE INSTALLATION

READ INSTRUCTIONS CAREFULLY BEFORE STARTING INSTALLATION. REMOVE CONTENTS FROM BOX AND VERIFY ALL PARTS ARE PRESENT. FAILURE TO IDENTIFY DAMAGE BEFORE INSTALLATION COULD LEAD TO A REJECTION OF ANY CLAIM. IF MISSING PARTS OR ANY DAMAGE FOUND, PLEASE TAKE A PICTURE FOR THE CLAIM PURPOSE. TO FILE YOUR CLAIM, PLEASE VISIT: WWW.TYGERAUTO.COM/CONTACT

Torque Value

Fastener Size	Class 8.8 Tightening Torque (ft-lbs)	Class 10.9 Tightening Torque (ft-lbs)
6mm	6-7	6-7
8mm	15-16	22-23
10mm	31-32	44-45
12mm	54-55	78-79
14mm	87-88	125-126

NOTE: Assistance is highly recommended. Factory installed or aftermarket "rock rails," side steps or running boards must be removed.

Parts List

- x1** Driver/left side TYGER Armor
- x1** Passenger/right side TYGER Armor
- x6** 8-1.25mm x 35mm Hex Bolts
- x6** 8mm Lock Washers
- x6** 8mm x 28mm x 3mm Flat Washers
- x12** 6-1.0mm x 25mm Hex Bolts
- x24** 6mm x 22mm x 2mm Flat Washers
- x12** 6-1.0mm Nylon Lock Nuts

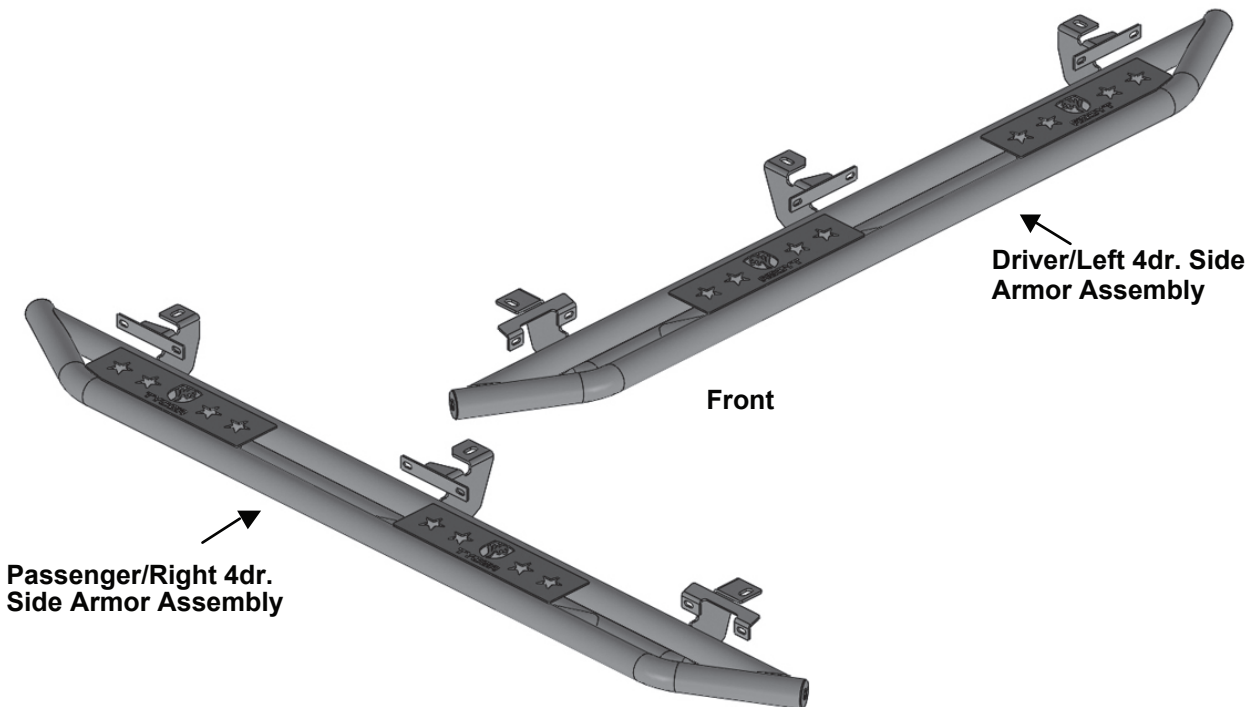



STEP 1

Start installation on the driver/left side of the vehicle. Locate the (3) pairs of factory mounting holes along the pinch weld, (Fig 1). The mounting brackets on the Side Armor attach to the holes in the pinch weld and the small factory threaded hole directly behind the pinch weld, (Figs 2-4).

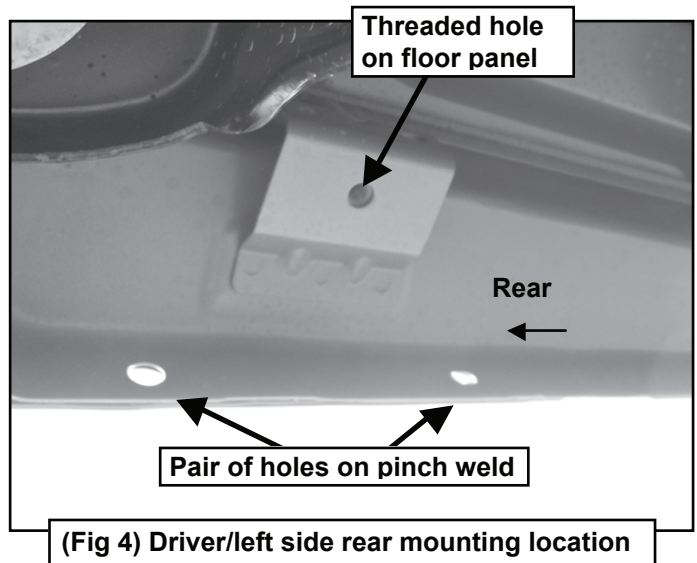
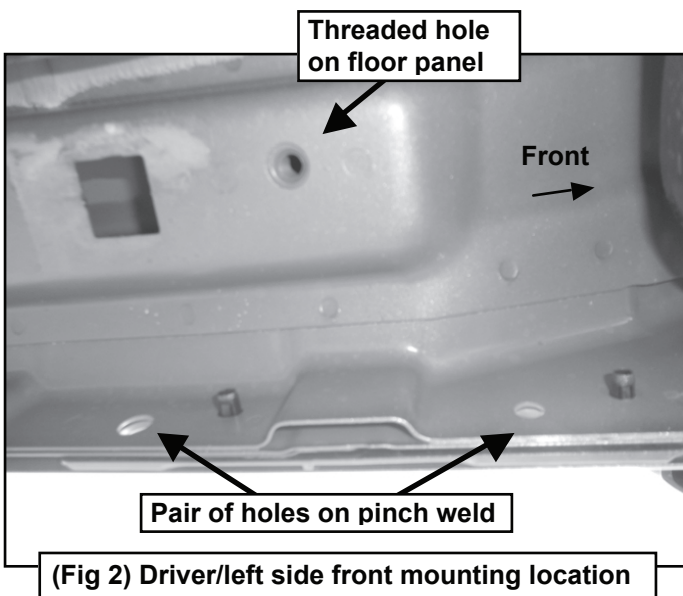
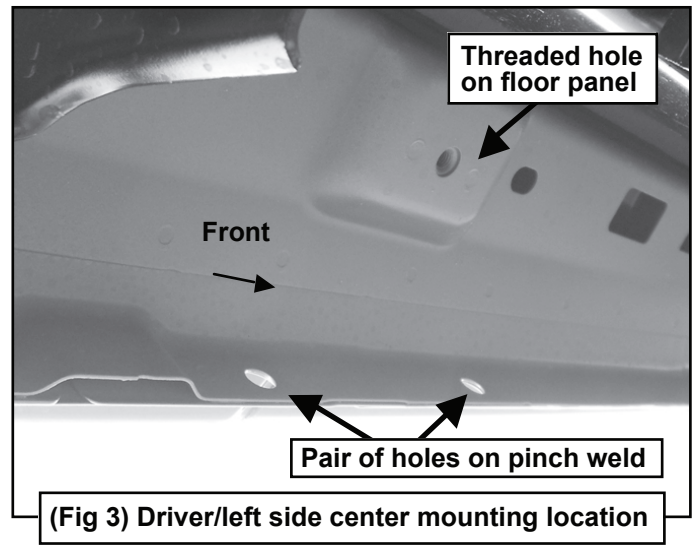
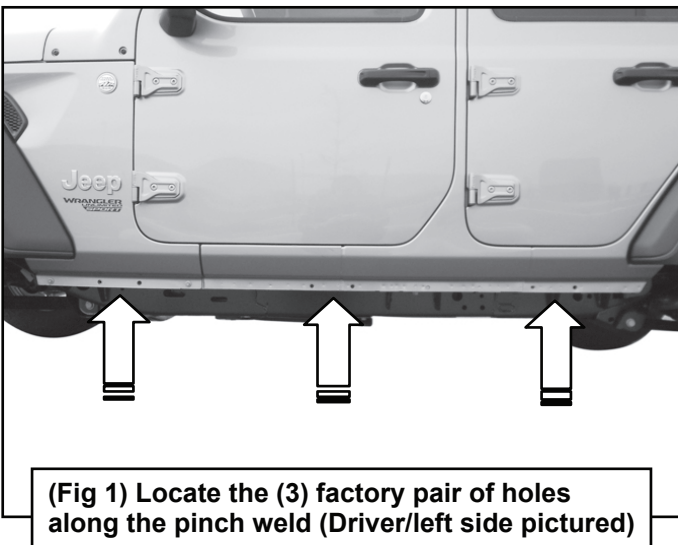



STEP 2

With assistance, hold the Driver/left Side Armor up in place against the back of the pinch weld. Line up the (3) welded brackets with the (6) factory holes in the pinch weld. Bolt the brackets to the back of the pinch weld with the included (6) 6mm x 25mm Hex Bolts, (12) 6mm Flat Washers and (6) 6mm Nylon Lock Nuts, (Figs 5-8). Leave hardware loose at this time.

NOTE: Insert Bolts from outside the pinch weld and out through the Bracket

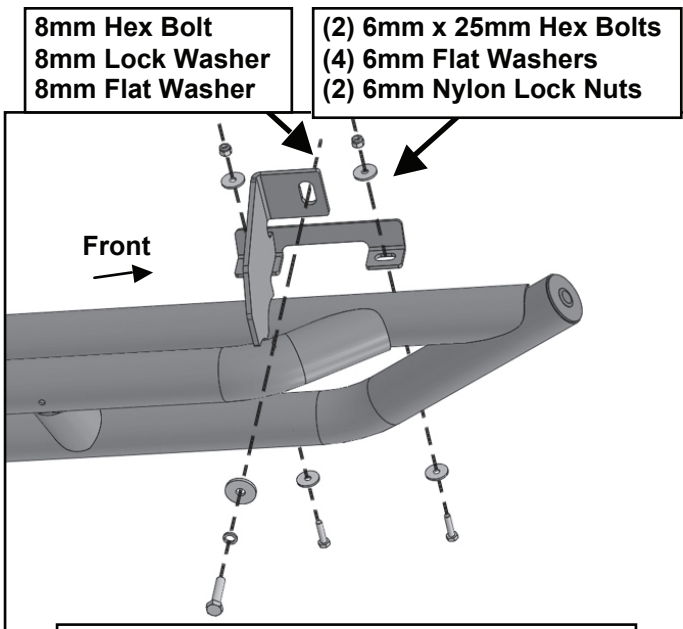

(Fig 5) Driver/left side front welded Bracket attached to pinch weld and inner floor panel

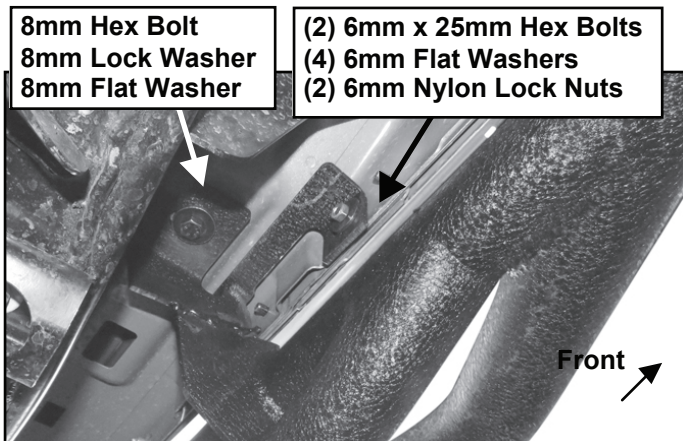

(Fig 6) Driver/left side front welded Bracket installed

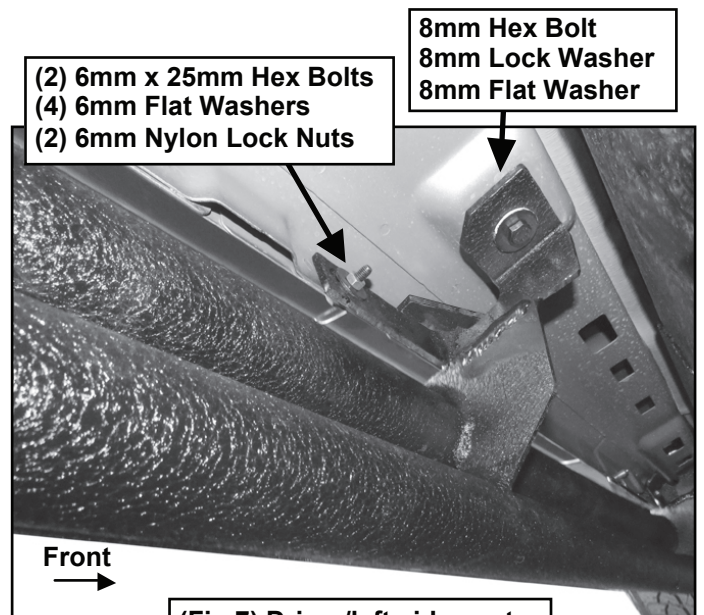

(Fig 7) Driver/left side center welded Bracket installed

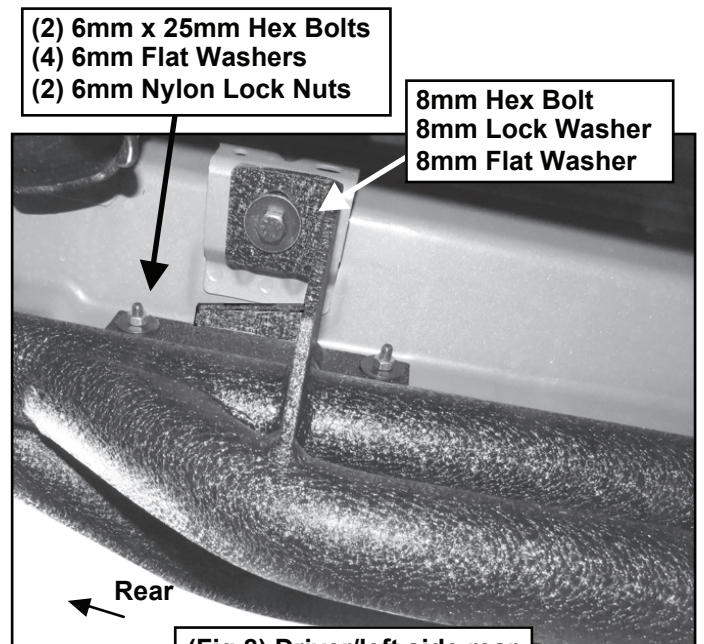

(Fig 8) Driver/left side rear welded Bracket installed

STEP 3

Bolt each top tab on the Side Armor to the vehicle with the included (1) 8mm x 35mm Hex Bolt, (1) 8mm Lock Washer and (1) 8mm Flat Washer, (Figs 5-8). Repeat for all locations.



TYGER[®]

STEP 4

Level and adjust the Side Armor and tighten all hardware.

STEP 5

Repeat Steps 1-4 for Passenger Side Armor installation

STEP 6

Do periodic inspections to the installation to make sure that all hardware is secure and tight.

