



TYGER RIDER®

TG-SS2C35087

Scan to Download the Latest Digital Version



Parts List

- x1** Driver/Left Sidebar **D**
- x1** Passenger/Right Sidebar **P**
- x6** Mounting Brackets
- x12** 8-1.25mm x 30mm Hex Bolts
- x12** 8-1.25mm x 25mm Combo Bolts
- x12** 8mm Lock Washers
- x12** 8mm x 24mm x 2mm Flat Washers

BEFORE INSTALLATION

READ INSTRUCTIONS CAREFULLY BEFORE STARTING INSTALLATION. REMOVE CONTENTS FROM BOX AND VERIFY ALL PARTS ARE PRESENT. FAILURE TO IDENTIFY DAMAGE BEFORE INSTALLATION COULD LEAD TO A REJECTION OF ANY CLAIM. IF MISSING PARTS OR ANY DAMAGE FOUND, PLEASE TAKE A PICTURE FOR THE CLAIM PURPOSE. TO FILE YOUR CLAIM, PLEASE VISIT: WWW.TYGERAUTO.COM/CONTACT

TORQUE VALUES

Fastener Size	Class 8.8 Torque (ft-lbs)	Class 10.9 Torque (ft-lbs)
6mm	6-7	6-7
8mm	15-16	22-23
10mm	31-32	44-45
12mm	54-55	78-79
14mm	87-88	125-126

Top View

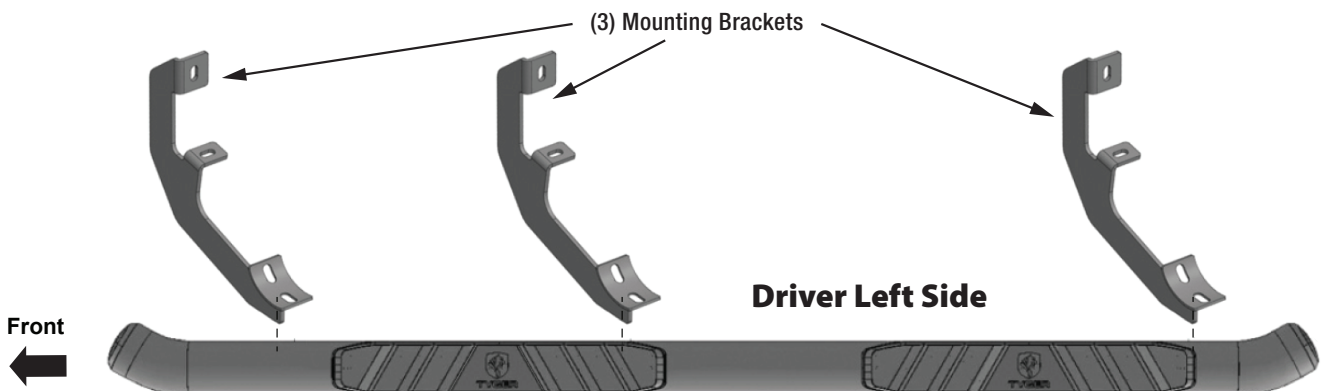
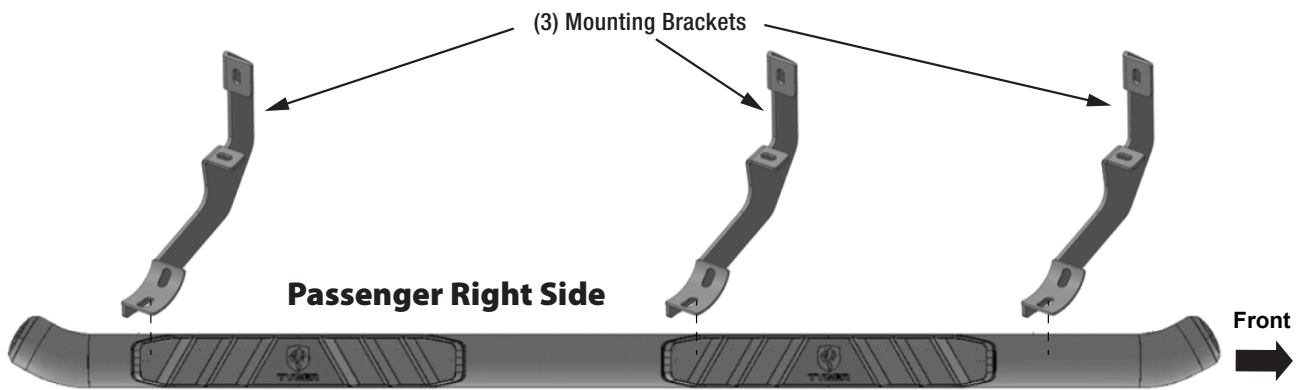

Bottom View

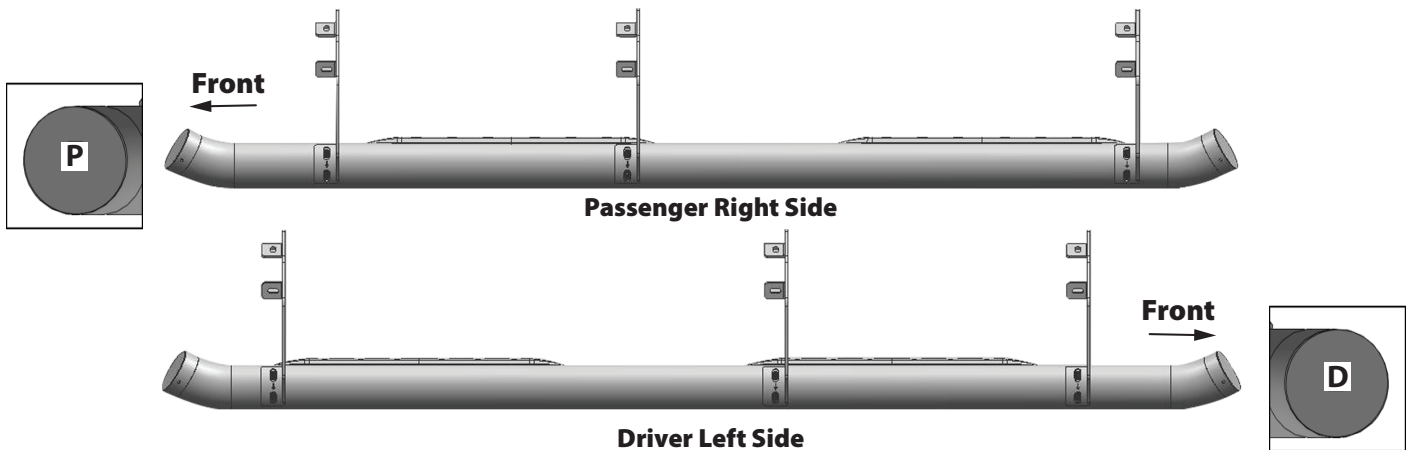

ATTENTION: Refer to **D** and **P** labelling on the side of the tubes to determine Driver and Passenger Rider

PROCEDURE:
 REMOVE CONTENTS FROM BOX. VERIFY ALL PARTS ARE PRESENT. READ INSTRUCTIONS CAREFULLY BEFORE STARTING INSTALLATION. ASSISTANCE IS RECOMMENDED.

STEP 1

Start the installation under the passenger/right side of the vehicle. Locate the 4 plugs along the bottom edge of the body. Mounting Brackets will attach to the **1st, 2nd and 4th** threaded mounting holes (Figs 1, 2 & 3). Remove the plastic plugs from each mounting location. Directly above each threaded hole is a top mounting location on the side of the body panel. Hold a Bracket up in place to help determine the mounting holes to use along the body.

NOTE: Thread an 8mm Hex Bolt into the threaded holes to clear paint as required.

Passenger/right Side Installation Pictured



(Fig 1) Remove plastic plugs (arrows) to uncover threaded holes in floor

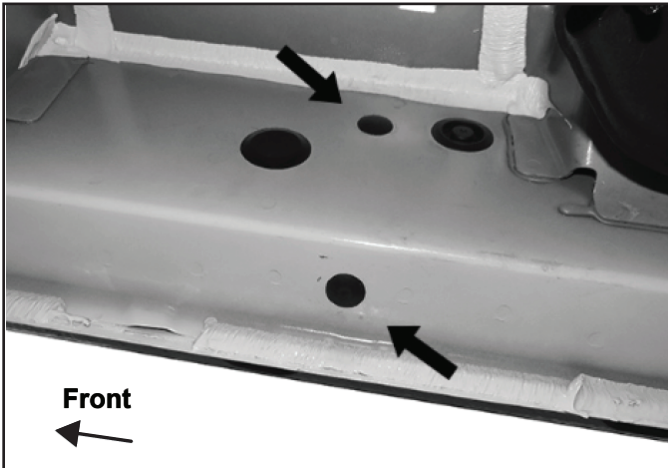

(Fig 2) Passenger/right 2nd (center) mounting location



(Fig 3) Passenger/right rear mounting location

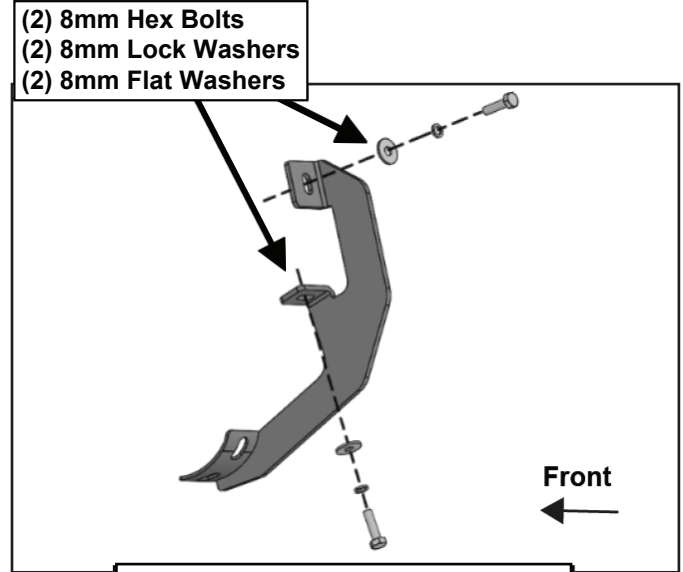

(Fig 4) Mounting Bracket illustration

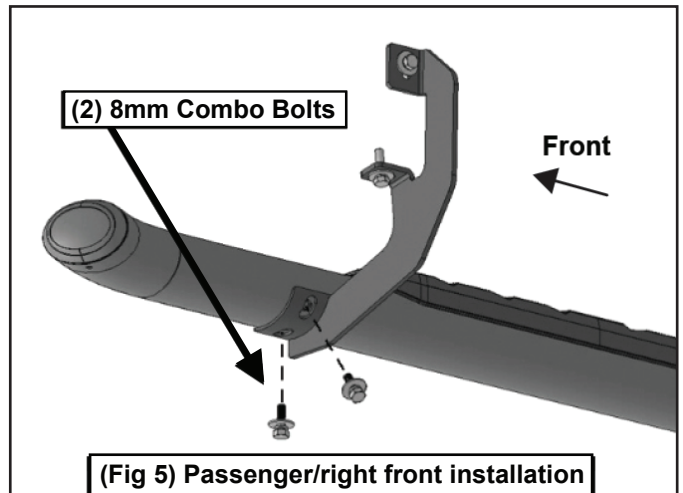

(Fig 5) Passenger/right front installation

STEP 2

Select (1) Mounting Bracket. Starting at the passenger/right side front of the vehicle, attach the Mounting Bracket to the factory threaded holes with (2) 8mm Hex Bolts, (2) 8mm Lock Washers and (2) 8mm Flat Washers (Figs 4, 5 & 6). DO NOT tighten hardware at this time.

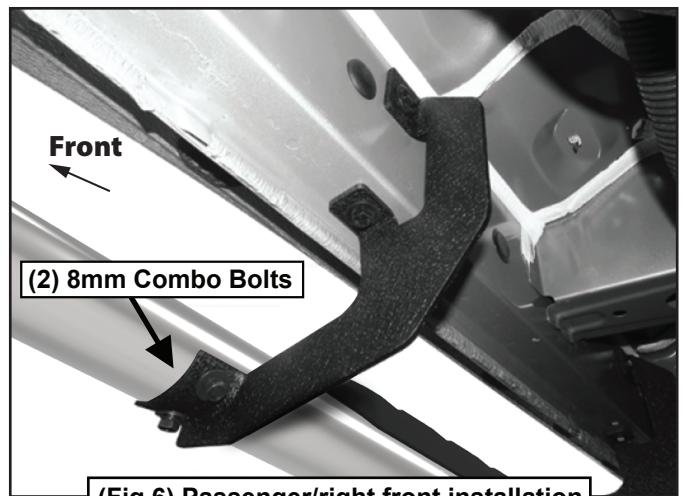

(Fig 6) Passenger/right front installation

STEP 3

Move along the body to the next mounting location. Repeat **STEPS 1 & 2** to attach a Mounting Bracket to the **2nd** (center) mounting location, (Figs 3 & 7). Repeat this **STEP** to attach a Bracket to the last mounting location toward the back of the cab (Figs 4 & 8).

Passenger/right Side Installation Pictured

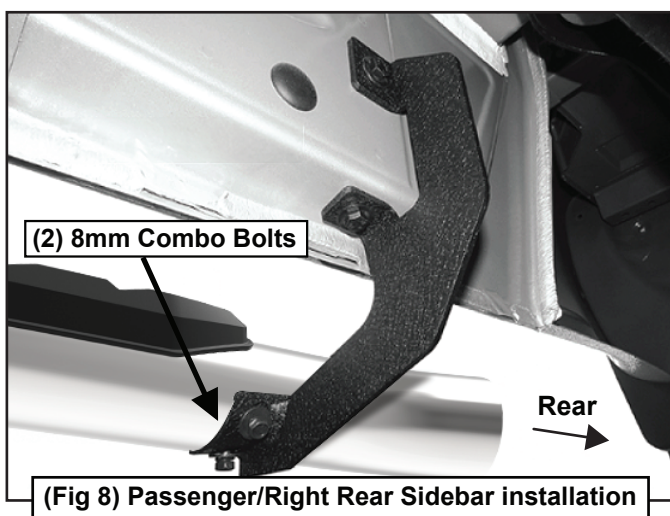
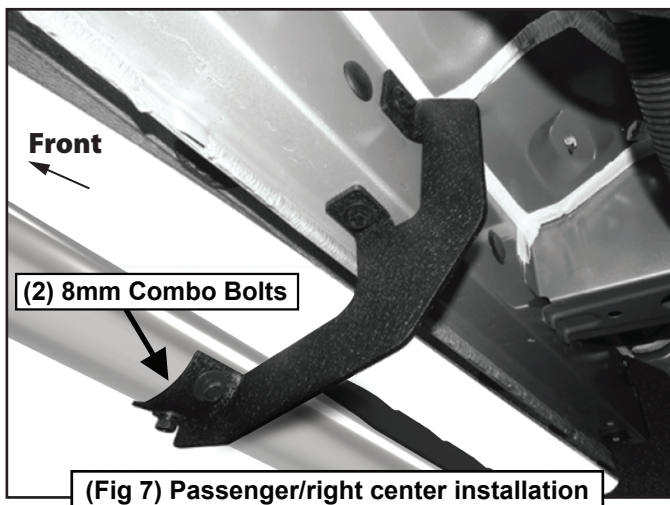

STEP 4

Select the passenger/right Sidebar. Use the illustration above to help determine the correct Sidebar.

NOTE: The rear step pad is closer to the end of the Sidebar. Place the Sidebar on top of the Brackets.

IMPORTANT: DO NOT slide, (front to back or rotate), the Sidebar on the Brackets or damage to the finish may result.

STEP 5

Attach the Sidebar to the Brackets with (6) 8mm Combo Bolts (Figs 5-8).

STEP 6

Level and adjust the Sidebar and fully tighten all hardware.

STEP 7

Repeat **STEPS 1-6** to install the Driver/Left Sidebar.

STEP 8

Do periodic inspections to the installation to make sure that all hardware is secure and tight.