



TYGER RIDER®

TG-SS2D35177

Scan to Download the Latest Digital Version



BEFORE INSTALLATION

READ INSTRUCTIONS CAREFULLY BEFORE STARTING INSTALLATION. REMOVE CONTENTS FROM BOX AND VERIFY ALL PARTS ARE PRESENT. FAILURE TO IDENTIFY DAMAGE BEFORE INSTALLATION COULD LEAD TO A REJECTION OF ANY CLAIM. IF MISSING PARTS OR ANY DAMAGE FOUND, PLEASE TAKE A PICTURE FOR THE CLAIM PURPOSE. TO FILE YOUR CLAIM, PLEASE VISIT: WWW.TYGERAUTO.COM/CONTACT

TORQUE VALUES

Fastener Size	Class 8.8 Torque (ft-lbs)	Class 10.9 Torque (ft-lbs)
6mm	6-7	6-7
8mm	15-16	22-23
10mm	31-32	44-45
12mm	54-55	78-79
14mm	87-88	125-126

- x1 Driver/Left Sidebar **D**
- x1 Passenger/Right Sidebar **P**
- x1 Driver/Left Front Mounting Bracket **A**
- x1 Passenger/Right Front Mounting Bracket **D**
- x1 Driver/Left Center Mounting Bracket **B**
- x1 Passenger/Right Center Mounting Bracket **E**
- x1 Driver/Left Rear Mounting Bracket **C**
- x1 Passenger/Right Rear Mounting Bracket **F**
- x1 Driver/Left Front Support Bracket (Long) **G**
- x1 Passenger/Right Front Support Bracket **I**
- x1 Driver/Left Rear Support Bracket (Short) **H**
- x1 Passenger/Right Rear Support Bracket (Short) **J**

- x6 12-1.75mm x 120mm Hex Bolts
- x6 12mm Lock Washers
- x6 12mm x 32mm OD x 3mm Flat Washers
- x4 10-1.5mm x 30mm Hex Bolts
- x4 10-1.5mm x 35mm Bolt Plates
- x12 10mm x 30mm OD x 2.5mm Flat Washers
- x8 10mm Lock Washers
- x8 10mm Hex Nuts
- x4 10mm Plastic Retainers
- x12 8-1.25mm x 25mm Combo Bolts
- x6 Spacer Washers

Parts List

Reference the letters printed on the brackets to determine mounting locations

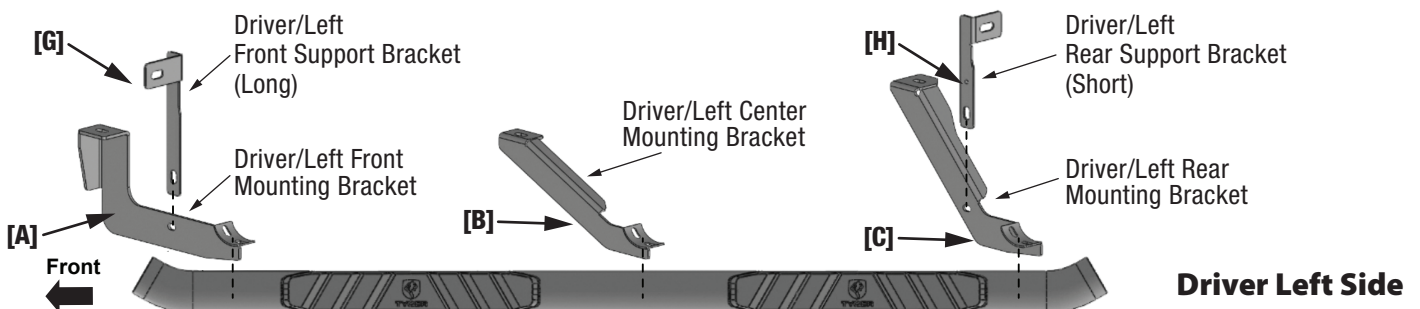
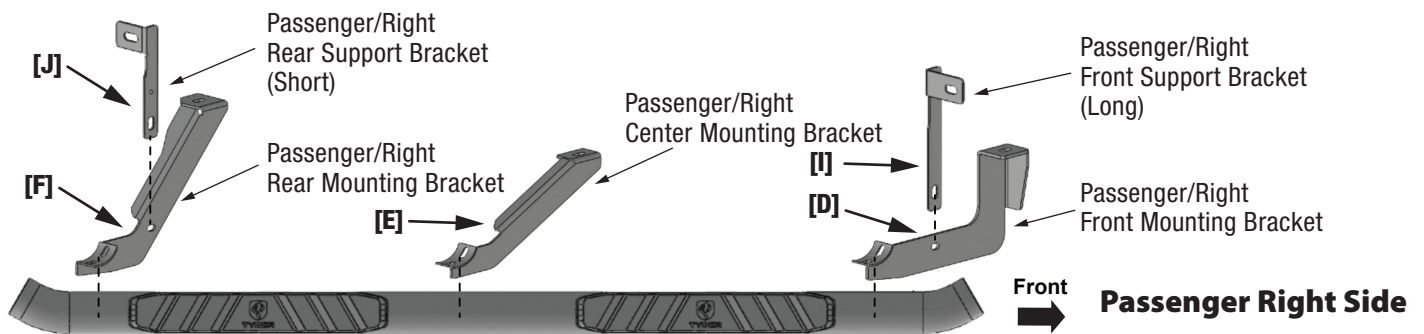

Bottom View

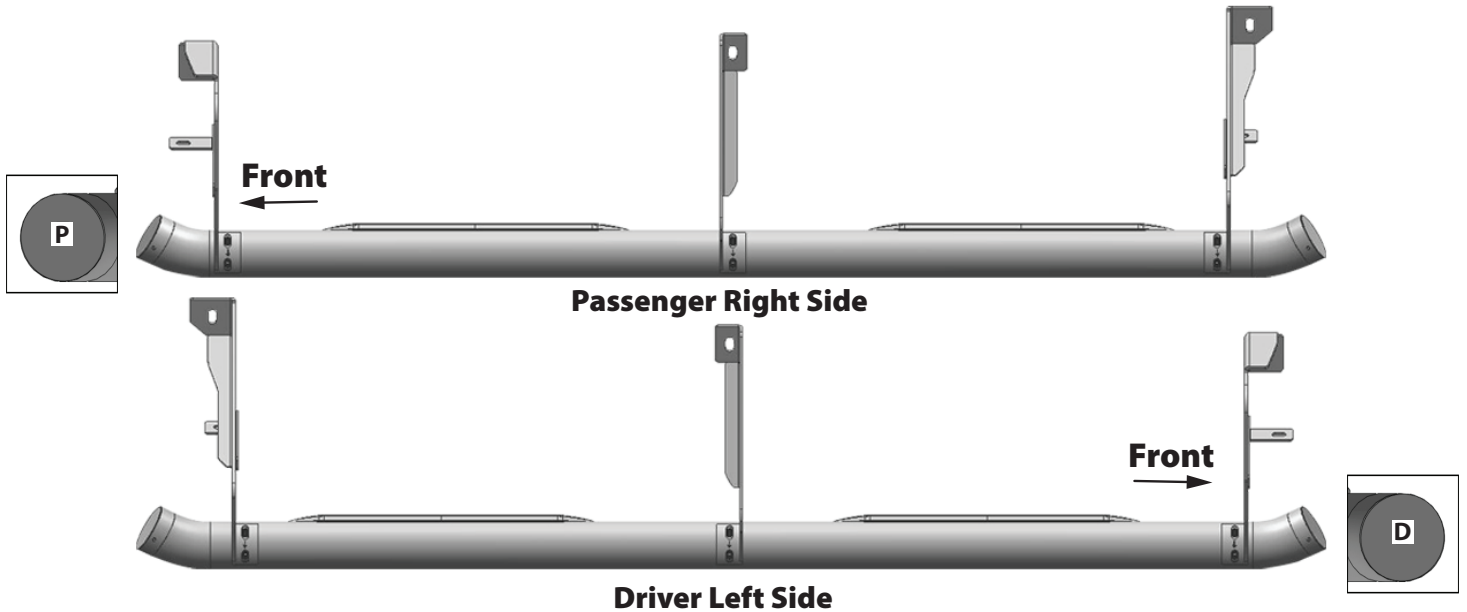

Distinguish the Driver and Passenger Side Steps by the **D** and **P** labeling on the end caps.

STEP 1

REMOVE CONTENTS FROM BOX. VERIFY ALL PARTS ARE PRESENT. READ INSTRUCTIONS CAREFULLY BEFORE STARTING INSTALLATION. ASSISTANCE IS RECOMMENDED.

STEP 2

Starting at the Passenger/Right side, remove the factory front body mount bolt with washer (Fig 1). Remove but DO NOT discard the rubber bushing from the factory bolt.

Passenger/Right Side Installation Pictured

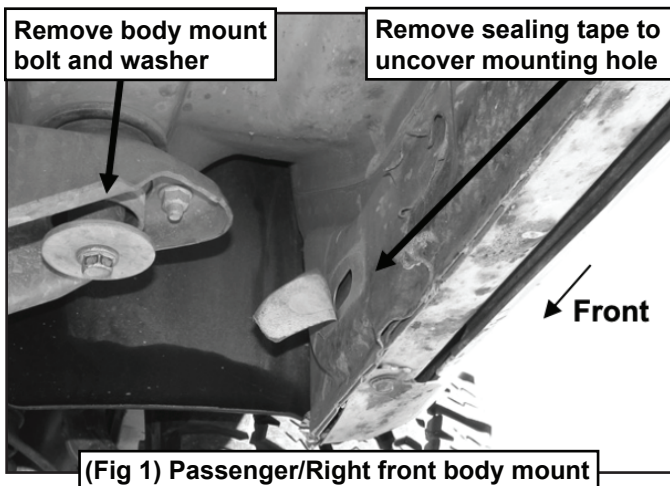

STEP 3

Select the Passenger/Right Front Mounting Bracket **[D]**. Insert (1) 12mm x 120mm Hex Bolt, (1) 12mm Lock Washer and (1) 12mm Flat Washer through the Mounting Bracket. Place (1) Large Spacer Washer (Fig 2), onto the Bolt then slide the rubber bushing onto the Hex Bolt against the Washer. Make sure that the Spacer Washer is between the Bracket and the factory rubber bushing (Fig 3).



IMPORTANT: Insert (1) Spacer Washer between each front and rear Mounting Bracket and factory rubber bushing (passenger side front Mounting Bracket pictured)

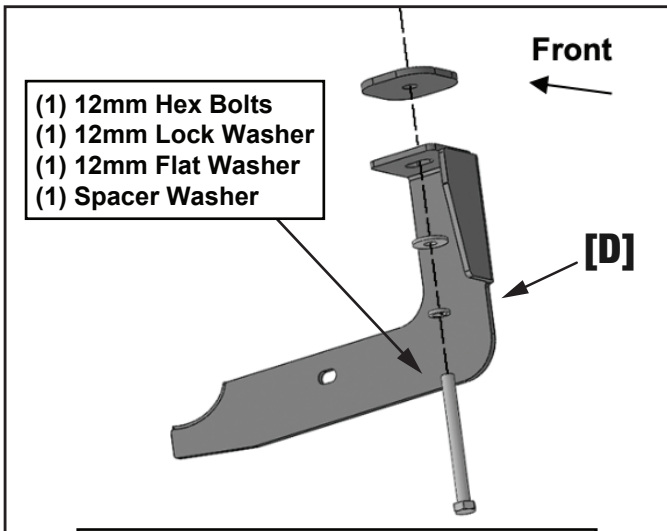

(Fig 3) Attach the Passenger/Right Front Mounting Bracket [D] to the front location

Passenger/Right Side Installation Pictured

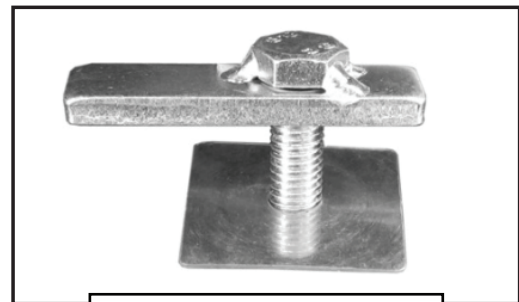

(Fig 4) Bolt Plate w/Retainer

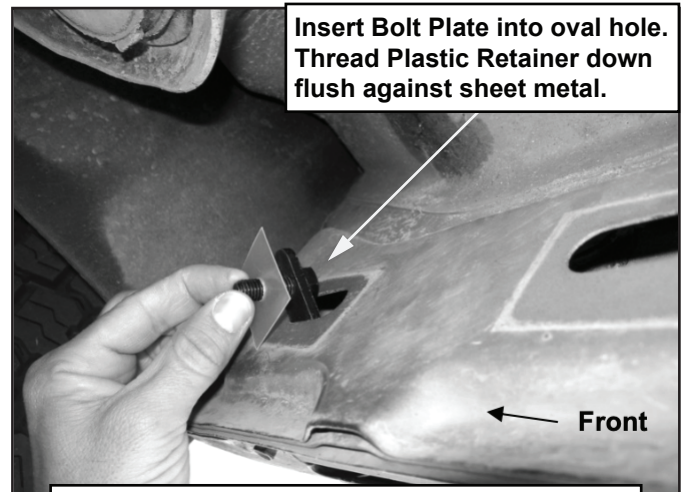

(Fig 5) Insert Bolt Plate into hole in body panel

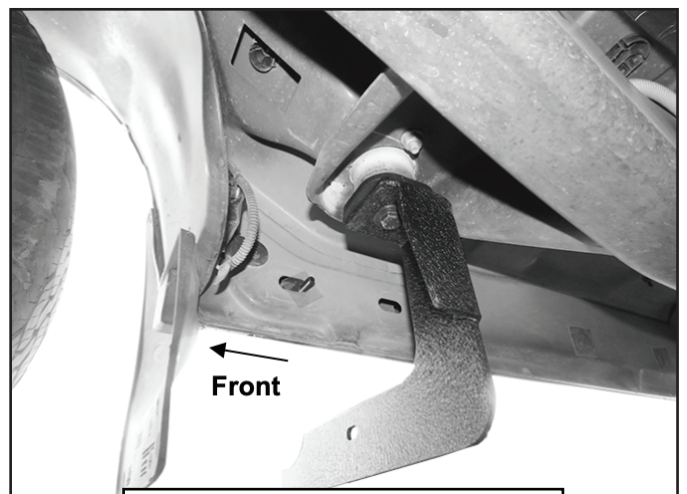

(Fig 6) Thread the Plastic Retainer tight against the body panel

STEP 4

Hold the Bracket and hardware up in place and attach to the factory body mount (Fig 3). DO NOT tighten hardware.

IMPORTANT: On 2005 and newer model years, the large washer on the factory body mount bolt may be removable, (DO NOT discard-must reinstall), and the bolt is long enough to go through the Mounting Bracket and properly thread into the body mount. It is the installer's responsibility to check length and to determine whether to reuse the factory body bolt or the included replacement 12mm x 120mm Hex Bolt.

STEP 5

Remove the tape covering the factory hole in the back side of the lower rocker panel near the Mounting Bracket (Fig1). Partially thread (1) Plastic Retainer onto (1) 10mm Bolt Plate (Fig 4). Insert the Bolt Plate into the factory hole on the body panel (Fig 5). Hold the Bolt Plate in place with one hand and continue to thread the Plastic Retainer down against the body panel to hold the Bolt Plate in place (Fig 6).

IMPORTANT: The Plastic Retainer is designed to prevent the Bolt Plate from falling into the body panel.

STEP 6

Select the Passenger/Right Front Support Bracket (long) **[I]** (Fig 7). Attach the Bracket to the Bolt Plate with (1) 10mm Flat Washer, (1) 10mm Lock Washer and (1) 10mm Hex Nut (Fig 8).

NOTE: Place the lower flat end of the Support Bracket **[I]** against the front facing side of the Mounting Bracket **[D]**. The bent tab on the top of the Support Bracket **[I]** should face the **front** of the vehicle. DO NOT tighten hardware.

Passenger/Right Side Installation Pictured

Passenger rear (short) **[J]**

Passenger front (long) **[I]**

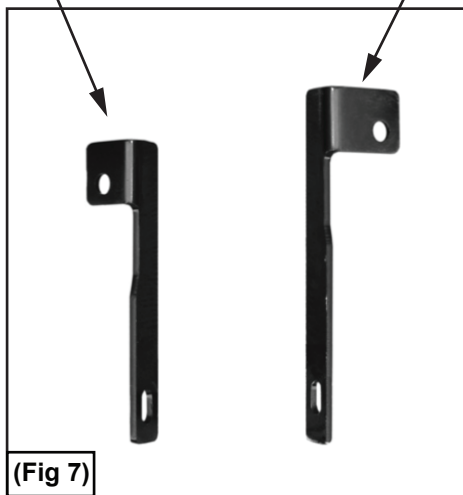

- (1) 10mm Bolt Plate
- (1) 10mm Plastic Retainer
- (1) 10mm Flat Washer
- (1) 10mm Lock Washer
- (1) 10mm Hex Nut

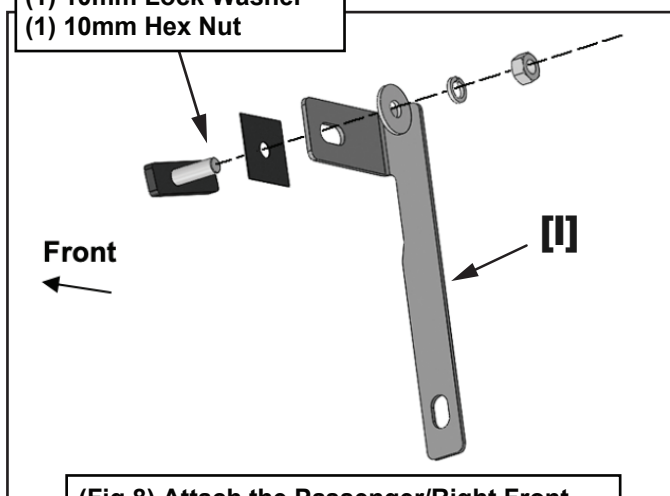

STEP 7

Attach the flat lower end of the Front Support Bracket **[I]** to the front of the Mounting Bracket **[D]** with (1) 10mm Hex Bolt, (2) 10mm Flat Washers, (1) 10mm Lock Washer and (1) 10mm Hex Nut (Figs 9 & 10). DO NOT tighten hardware.

- (1) 10mm Hex Bolt
- (2) 10mm Flat Washers
- (1) 10mm Lock Washer
- (1) 10mm Hex Nut

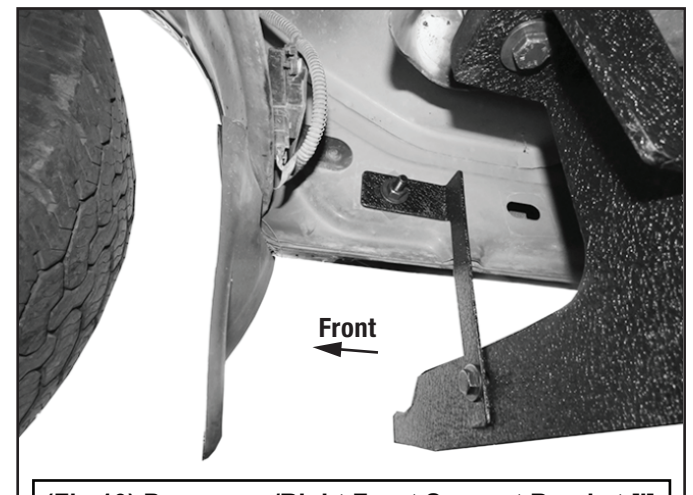
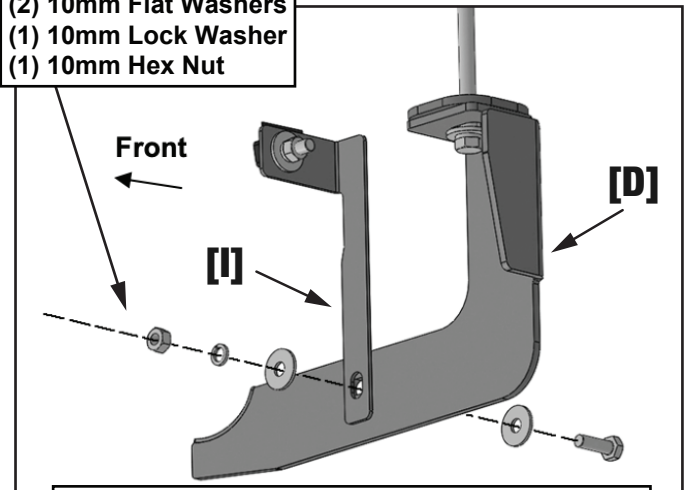

STEP 8

Move to the center body mount of the cab. Select the Passenger/Right Center Mounting Bracket **[E]**. Repeat **STEPS 2-4** to attach the Bracket to the center body mount (Figs 11 & 12). DO NOT tighten hardware.

Passenger/Right Side Installation Pictured

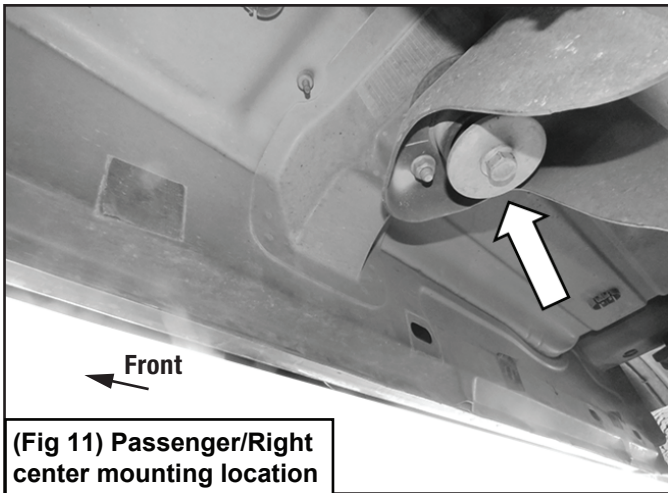

(Fig 11) Passenger/Right center mounting location

- (1)12mm Hex Bolts
- (1)12mm Lock Washer
- (1)12mm Flat Washer
- (1)Spacer Washer

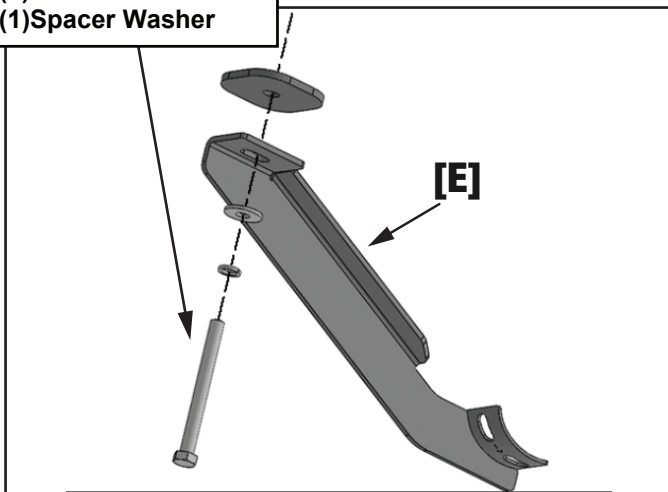

(Fig 12) Attach the Passenger/Right Center Mounting Bracket [E] to the center location

STEP 9

Move to the rear body mount at the back of the cab (Fig 13). Select the Passenger/Right Rear Mounting Bracket [F] and (1) Spacer Washer. Repeat **STEPS 2-4** to attach the Bracket to the rear body mount (Fig 14). DO NOT tighten hardware.

Passenger/Right Side Installation Pictured

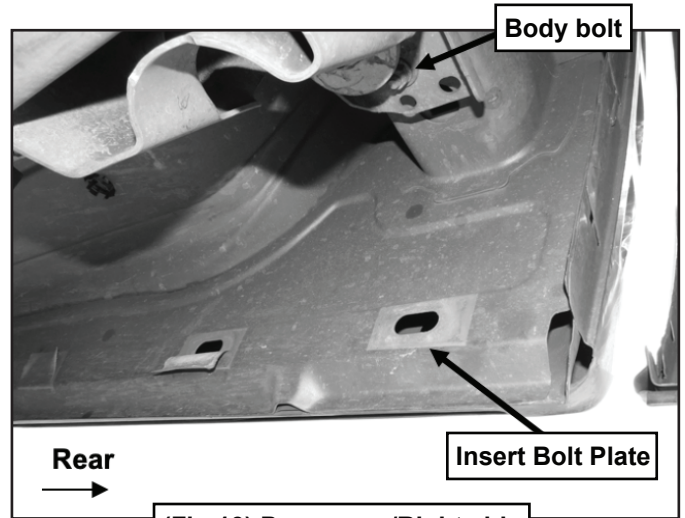

(Fig 13) Passenger/Right side Rear mounting location

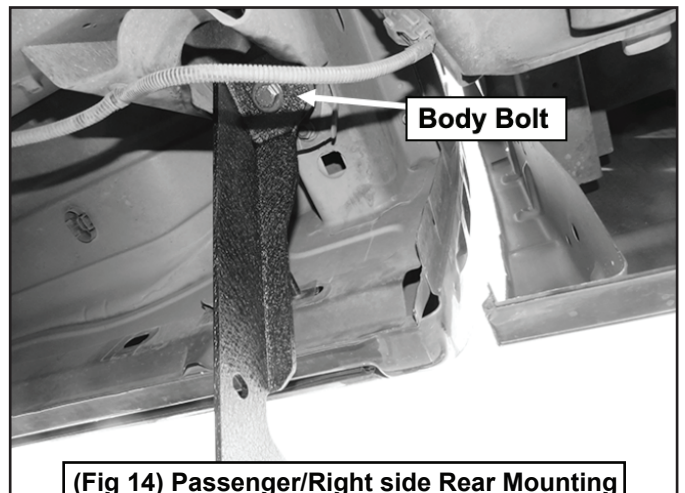

(Fig 14) Passenger/Right side Rear Mounting Bracket [F] attached to the rear body mount

STEP 10

Repeat **STEPS 5-7** attach the Passenger/Right Rear Support Bracket (short) [J] (Figs 4, 7, 14-16).

NOTE: Place Support Bracket [J] against the front facing side of the Mounting Bracket [F]. The bent tab on the top of the rear Support Bracket [J] should face the rear of the vehicle. DO NOT tighten hardware.

Passenger/Right Side Installation Pictured

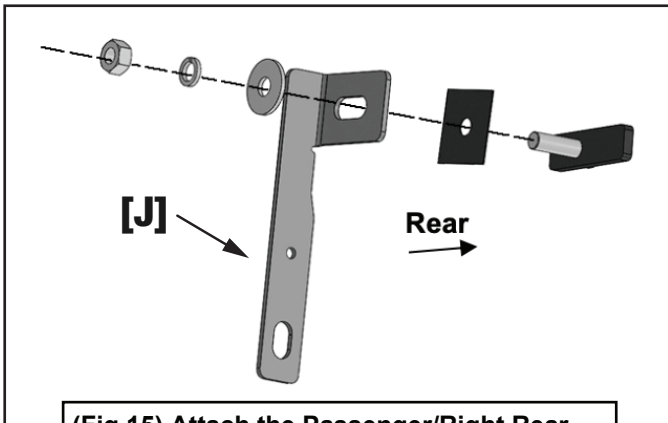

(Fig 15) Attach the Passenger/Right Rear Support Bracket (Short) [J] to the Bolt Plate

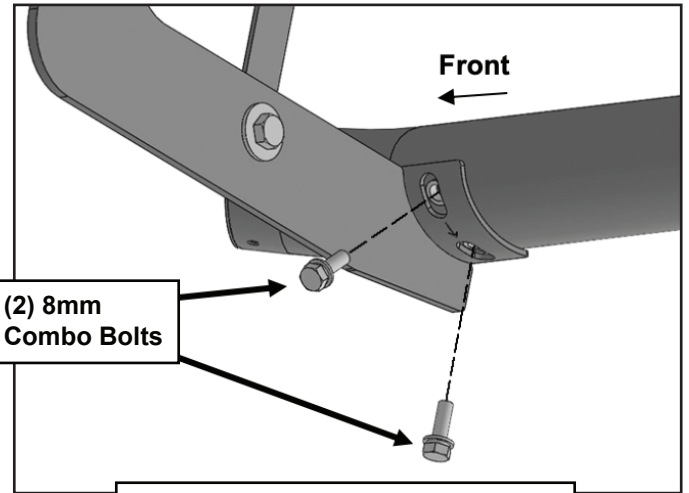

(Fig 17) Attach the Passenger/Right Sidebar to the Mounting Brackets

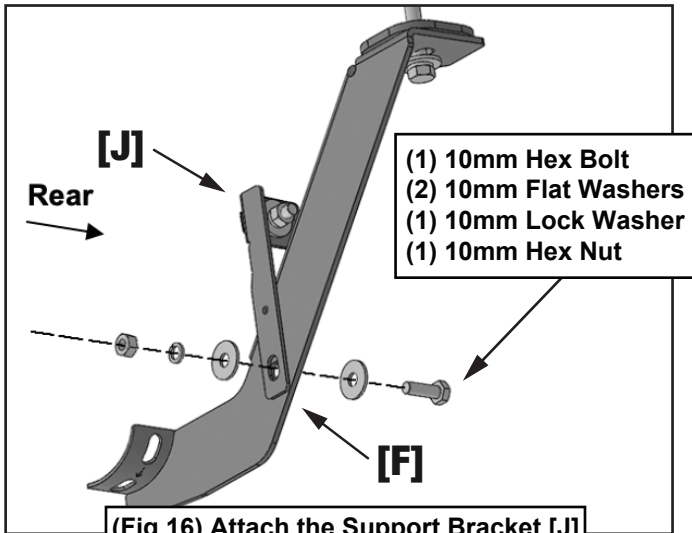

(Fig 16) Attach the Support Bracket [J] to the Mounting Bracket [F]

STEP 12

Level and adjust the Sidebar and tighten all hardware.

STEP 13

Repeat **STEPS 2-12** to attach the Driver/Left Sidebar.

STEP 14

Do periodic inspections to the installation to make sure that all hardware is secure and tight.

STEP 11

Select the Passenger/Right Sidebar. The front stepping pad is farther away from the front end of the Sidebar. With assistance, carefully position the Sidebar onto the Mounting Brackets.

NOTE: DO NOT slide or rotate Sidebar on Mounting Brackets or damage to the finish may result. Attach the Sidebar to the Mounting Brackets with (6) 8mm Combo Bolts (Fig 17). DO NOT tighten hardware.