



TYGER RIDER®

TG-SS2N35207

Scan to Download the Latest Digital Version



BEFORE INSTALLATION

READ INSTRUCTIONS CAREFULLY BEFORE STARTING INSTALLATION. REMOVE CONTENTS FROM BOX AND VERIFY ALL PARTS ARE PRESENT. FAILURE TO IDENTIFY DAMAGE BEFORE INSTALLATION COULD LEAD TO A REJECTION OF ANY CLAIM. IF MISSING PARTS OR ANY DAMAGE FOUND, PLEASE TAKE A PICTURE FOR THE CLAIM PURPOSE. TO FILE YOUR CLAIM, PLEASE VISIT: WWW.TYGERAUTO.COM/CONTACT

TORQUE VALUES

Fastener Size	Class 8.8 Torque (ft-lbs)	Class 10.9 Torque (ft-lbs)
6mm	6-7	6-7
8mm	15-16	22-23
10mm	31-32	44-45
12mm	54-55	78-79
14mm	87-88	125-126

Parts List

- x1** Driver/Left Sidebar **D**
- x1** Passenger/Right Sidebar **P**
- x3** Driver/Left Mounting Brackets **[A]**
- x3** Passenger/Right Mounting Brackets **[B]**
- x12** 8-1.25mm x 25mm Combo Bolts
- x12** 8mm x 24mm OD x 2mm Flat Washers
- x12** 8mm Flange Nuts

Reference the letters printed on the brackets to determine mounting locations

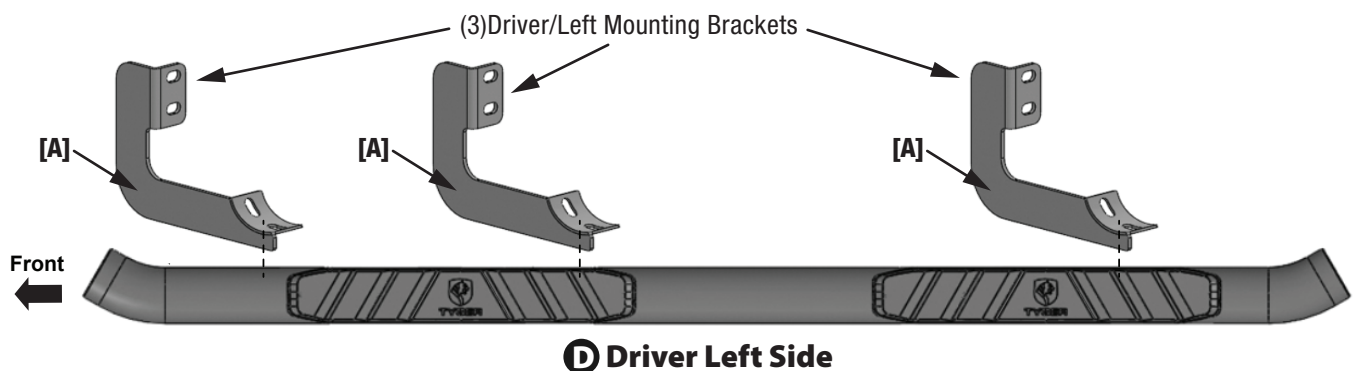
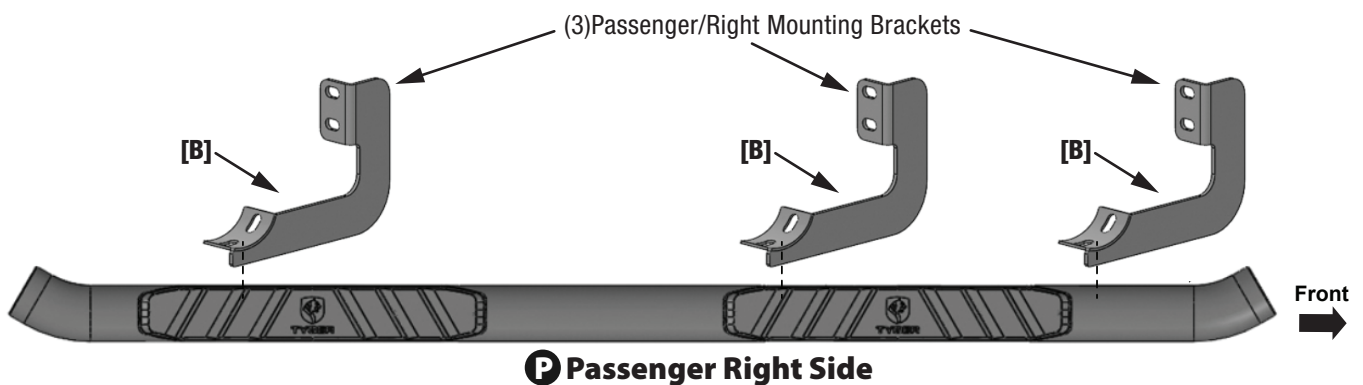

Bottom View

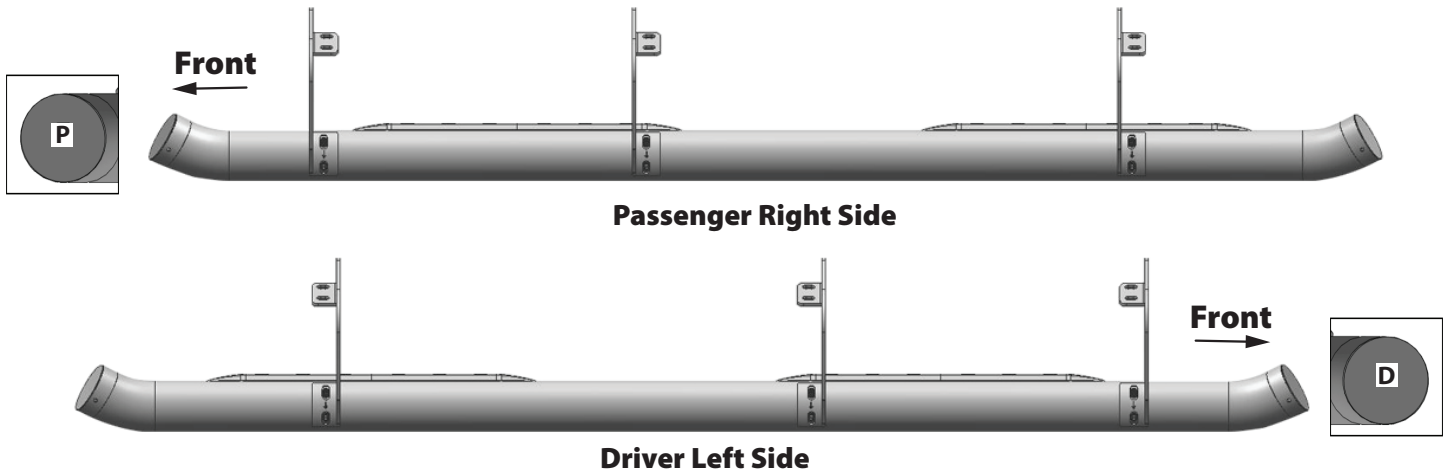

Distinguish the Driver and Passenger Side Steps by the **D** and **P** labeling on the end caps.

STEP 1

REMOVE CONTENTS FROM BOX. VERIFY ALL PARTS ARE PRESENT. READ INSTRUCTIONS CAREFULLY. CLEAN MOUNTING STUDS WITH WIRE BRUSH TO REMOVE PAINT AND DEBRIS.

STEP 2

Starting on the Passenger/Right side front of the vehicle (Fig1).

Passenger Side Installation Pictured

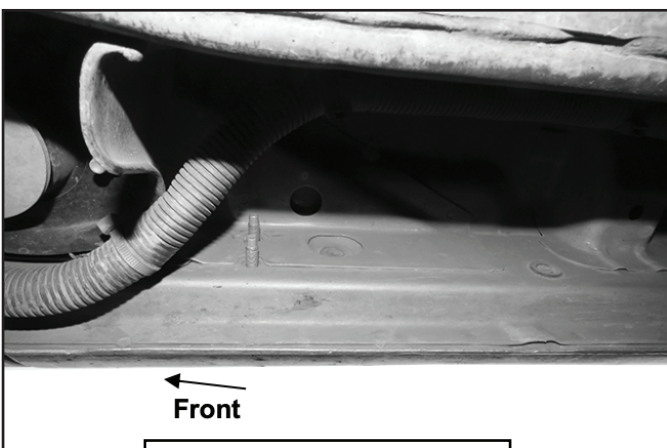

(Fig 1) Passenger/Right side front mounting location

Attach (1) Passenger/Right Mounting Bracket **[B]** to the Front Location with (2) 8mm Flat Washers and (2) 8mm Flange Nuts. (Fig 2A)

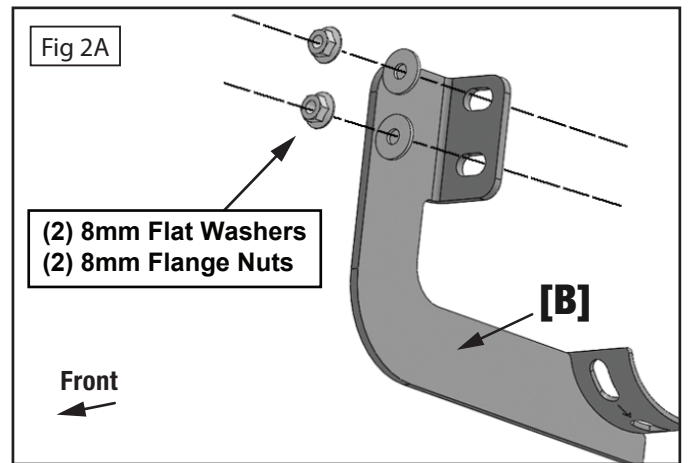

ATTENTION:
Some Frontier models have front factory studs that are too short to fit both Flat Washers and Flange Nuts. In this case, **omit the Flat Washers and only install the Flange Nuts.** (Fig 2B)

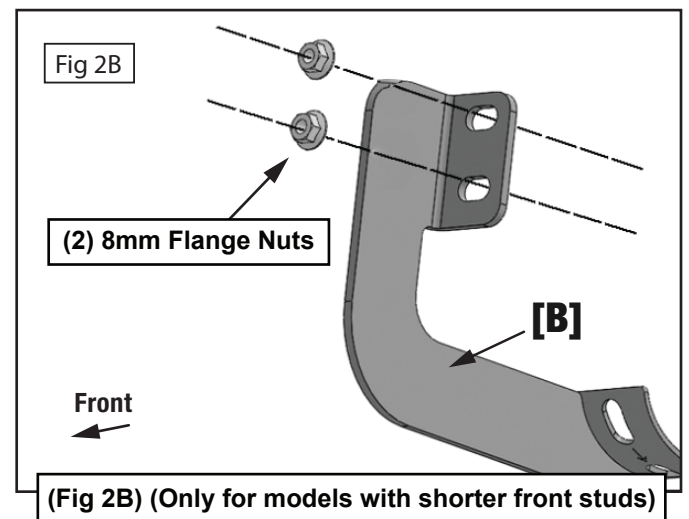

(Fig 2B) (Only for models with shorter front studs)

STEP 3

Repeat **STEP 2** to attach the remaining Passenger/Right Mounting Brackets **[B]** to the center and rear locations (Figs 3 & 4).

Passenger Side Installation Pictured

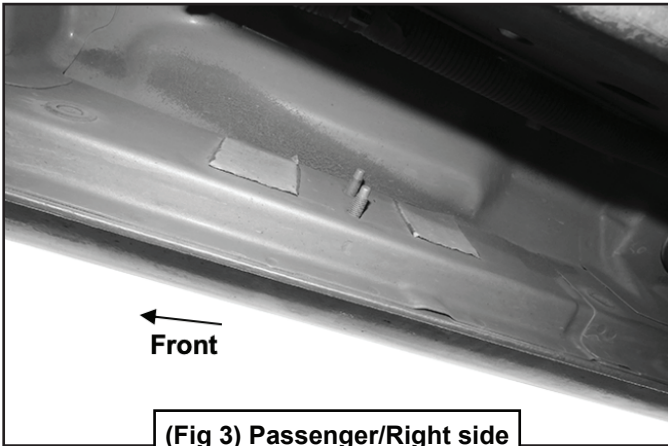

(Fig 3) Passenger/Right side center mounting location

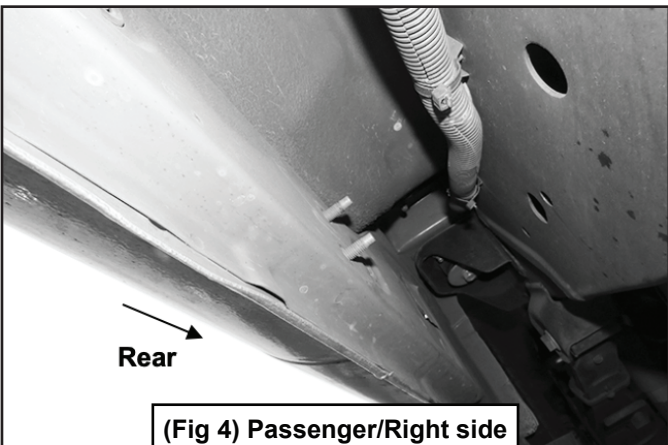

(Fig 4) Passenger/Right side rear mounting location

STEP 4

Select the Passenger/Right Sidebar. Carefully place Sidebar on the brackets.

IMPORTANT: DO NOT slide or rotate Sidebar on cradles, or damage to the finish may result. Attach Sidebar to the Mounting Brackets with (6) 8mm Combo Bolts (Figs 5 & 6). DO NOT tighten hardware at this time.

Passenger Side Installation Pictured

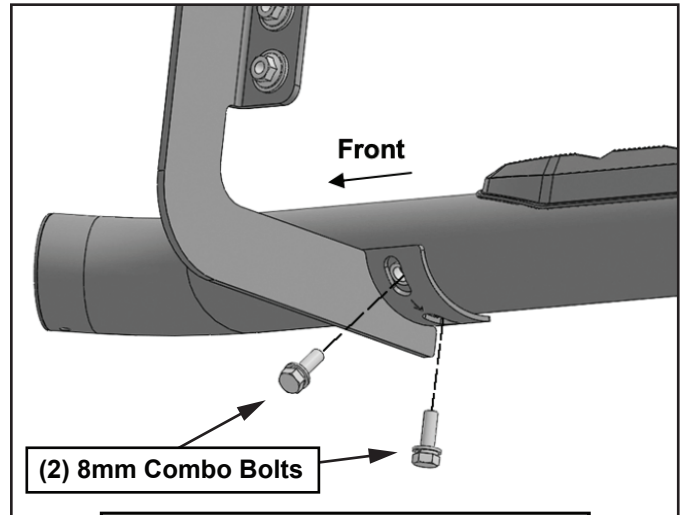

(2) 8mm Combo Bolts

(Fig 5) Attach the Passenger/Right Sidebar to the Mounting Brackets



(Fig 6) Sidebar attached to the Front Mounting Bracket

STEP 5

Level and adjust the Sidebar and tighten all hardware.

STEP 6

Repeat **STEPS 1-5** to attach the Driver/Left Sidebar.

STEP 7

Do periodic inspections to the installation to make sure that all hardware is secure and tight.